

**244LD LevelStar Intelligent Buoyancy Transmitter for Level, Interface and Density – HART® and FOUNDATION Fieldbus**



*The intelligent transmitter 244LD LevelStar is designed to perform continuous measurements for liquid level, or density of liquids in the process of all industrial applications. The measurement is based on the proven Archimedes buoyancy principle. Measuring values can be transferred analog and digital. Digital communication facilitates complete operation and configuration via PC or control system. Despite extreme temperatures, high process pressure and corrosive liquids, the 244LD measures with consistent reliability and high precision. It is approved for installations in contact with explosive atmospheres.*

**FEATURES**

- ▶ HART® Communication, 4 to 20 mA, or Foundation Fieldbus
- ▶ Configuration via FDT-DTM
- ▶ Multilingual full text graphic LCD
- ▶ IR communication as a standard
- ▶ Easy adaptation to the measuring point without calibration at the workshop
- ▶ Linear or customized characteristic
- ▶ 32 points linearization for volumetric measurement
- ▶ Approved for SIL 2 applications (at HART®)
- ▶ Back documentation of measuring point
- ▶ Continuous self-diagnostics, Status and diagnostic messages
- ▶ Configurable safety value
- ▶ Local display in %, mA, or physical units
- ▶ Process temperature from –196°C to +500°C
- ▶ Materials for use with aggressive media
- ▶ Micro sinter metal sensor technology

*Equipment should be installed, operated, serviced, and maintained only by qualified personnel.  
No responsibility is assumed by Schneider Electric for any consequences arising from the use of this material.*

Figure 1. PACTWARE Screens

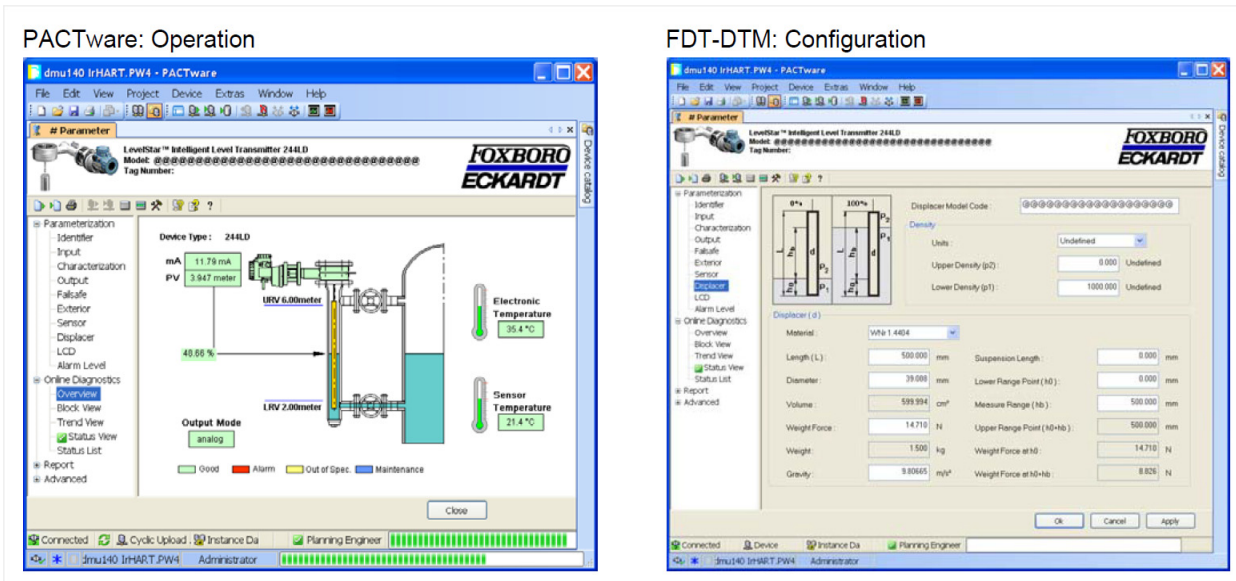

Supply via Power Supply Unit with Communication; Ex

Figure 2. Supply via power supply unit with communication; Ex

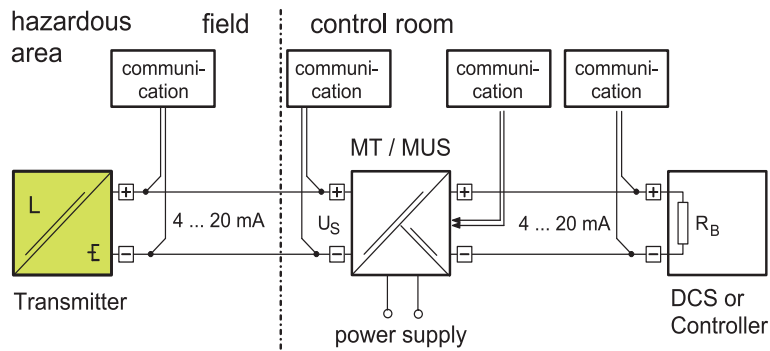

## Direct Supply with Communication; not Ex

Further supply circuits see Master Instruction document.

Figure 3. Direct supply with communication; not Ex

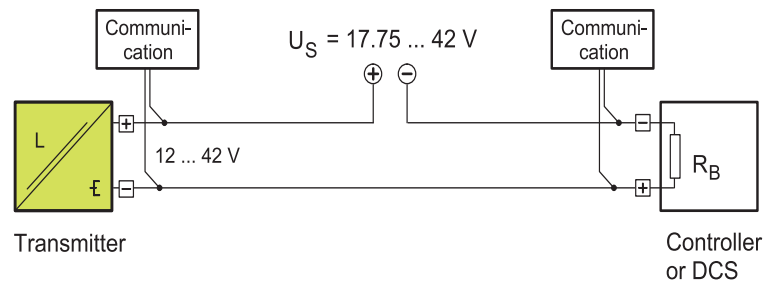

Maximum Voltage Supply is

- ▶ 42 V for non-Ex as shown in Figure 3
- ▶ 24 V for PA/FF ATEX
- ▶ 30 V for HART® Ex
- ▶ 32 V for PA/FF/HART® CSA approval

## CONNECTIONS, OPERATIONAL ELEMENTS

Figure 4. Connections, Operational Elements

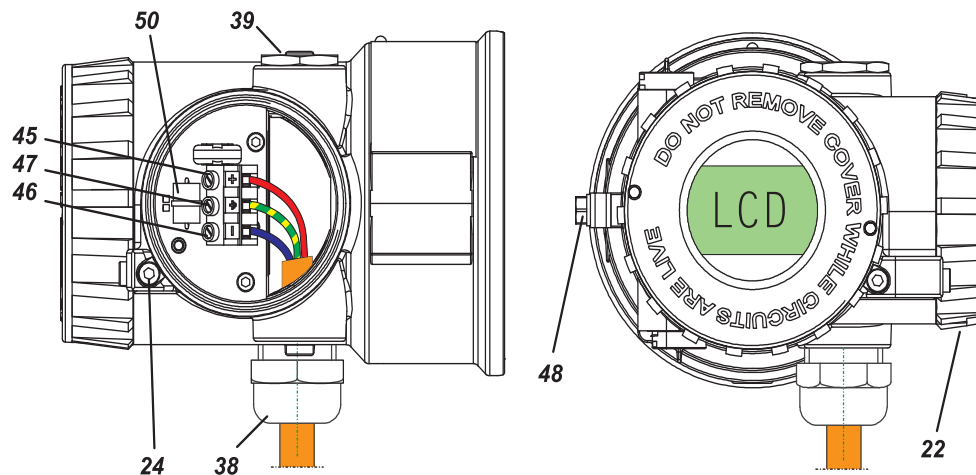

- |  |   |
|--|---|
| <p>22 Connecting compartment cover</p> <p>24 Cover lock</p> <p>38 Cable gland (permitted cable diameter 6 to 12 mm)</p> <p>39 Cover screw</p> <p>45 Connection terminal "+" wire cross</p> <p>46 Connection terminal "-" section</p> | <p>47 Ground terminal max. 2.5 mm<sup>2</sup> Test sockets (Ø 2 mm) integrated in terminal block</p> <p>48 External ground terminal</p> <p>50 Overvoltage protection (if present)</p> |
|--|---|

TECHNICAL DATA

Data refer to the sensor material Type 316L (1.4404). Refer to Explosion protection certificates.

Communication FOUNDATION Fieldbus H1

Input / Output

Measuring ranges	50 mm to 50 m, upper and lower range value continuously adjustable
Standard lengths of Displacer (204DE)	350 to 3000 mm, 14 to 120 in; further lengths on request
Weight of displacer (a)	max. 25 N
Measuring span	2 to 20 N continue adjustable (to 1 N on request)
<b>Span Ratio</b>	
Turn-down	1:1 to 1:10 (1:20 on request)
Accuracy (b)	±0.2% at Level, Density and Interface measurement. Increased accuracy with customized adjustment
Transfer function	linear or customized with up to 32 setpoints

- a. For measurement of interface or density: weight 25 N + buoyant force at lowest density
- b. Accuracy according to ANSI / ISA - S51.1 - 1979

Configuration

- ▶ with FDT-DTM per HART® protocol
  - ▶ via 2-wire connection 4-20 mA
  - ▶ via IR communication
- ▶ with multi-lingual, full graphic LCD display with %, mA, physical units and 2 from the outside-to-use buttons

Load:  $RB_{max} = (U_S - 12 V) / 23 mA$

Connection	twisted and shielded two wire cable according to recommendation based on IEC 1158-2
Supply voltage $U_S$	9 to 32 V DC (a), $V_{pp} \leq 1\%$
Operating current	10.5 mA ± 0.5 mA (base current)
Digital communication	FF specification ITK Profile 6, Link-Master (LAS), function blocks 2AI, PID, IS, OS, AR
Signal amplitude	±8 mA
Fault current	≤ 13 mA
Operating values	according to IEC 1158-2
Bus connection	Fieldbus interface based on IEC 1158-2
Power supply	Power supply is achieved dependent on the application by means of segment coupler
<b>Configuration</b>	
Software	National Instruments; NI-FBUS Configurator
Hardware	FBUS interfaces from National Instruments (USB-FBUS and PCMCIA-FBUS)
Control systems	FOUNDATION Fieldbus H1 compatible
<b>Failure Handling</b>	
Substitute value	last value or safety value
Safety value	adjustable –110 to 110% of out
Reset substitute value	automatically or manual

- a. With explosion proof device 9 to 24 V DC

**Communication HART®**

Connection	Two-wire system
Supply voltage U <sub>S</sub> (a)	> 12 V + R <sub>b</sub> (b)0.025 A
Current sink	max. 24 mA
Signal range	4 to 20 mA
Operating range	3.8 to 20.5 mA (according to NE 43)
Critical error alarms in the 2-wire Communication	< 3.6 mA and > 21 mA
<b>HART® Protocol</b>	
2-wire	1200 Baud, HART® compliant
IR communication	19200 Baud
Communication Hardware	
▶ Handterminal	HT 375/475
▶ PC Software	WIN xx and FDT/DTM

- a. U<sub>S</sub> (max) with explosion proof device < 30 V, otherwise < 42 V
- b. R<sub>b</sub> is the total burden resistor for lines, HART® measurement resistor and communication.

**Operating Conditions<sup>(1)</sup>**

Process temperature	-196°C to 500°C
Pressure rating ▶ according to DIN ▶ according to ANSI	PN 16, 40, 63, 100, 160, 250 Class 150, 300, 600, 900, 1500
Ambient temperature (a)	Exd : T4 : -40°C...119°C T6 :-40°C....80°C  Exi : T4 :-40°C...80°C T6 :-40°C...+75°C (b)
Relative humidity	up to 100%
Condensation	permitted
Transportation storage temperature	-40°C to 85°C
Protection	IP 66 (according to DIN 40 050)

- a. It is important to ensure that the maximum permissible temperature of the electronics housing of 85°C and as that of the internal sensor/measuring cell of 120°C is not exceeded.
- b. Display not readable at T < -20°C or T > 70°C

The device can be operated at a class D2 location in accordance with DIN IEC 654, part 1.

1. Not with all materials - See "Comparison of Material"

**Operation Condition Effects**

Ambient temperature ▶ Zero ▶ Span	-10°C ... +70°C < 0.1% / 10 K (a) < 0.07% / 10 K
Total	
$\left(0.1 \frac{\text{max. span}}{\text{adjusted sp.}} \pm 0.07 \frac{\text{Measured value}}{\text{adjusted span}}\right) \% / 10 \text{ K}$ <small>(sp. = measuring span)</small>	
< -10°C / > +70°C	twice the value
Process temperature	< 0.1% / 10 K (a)
Operating pressure	no influence (vacuum resistant)

- a. For maximum measuring span

**Transitional Behavior**

<b>Dynamic behavior</b>	
▶ Damping (90%-time) ▶ Switch-on time ▶ Step response (63%-time) with damping 0s	0 to 32 s 7 s 250 ms
Update rate	10 / s
Long term stability	< 0.2% / 6 months at 20°C (a)
Noise suppression	
▶ Common mode voltage ▶ Common mode rejection ▶ Series mode rejection ▶ Filter	< AC 250 V <sub>eff</sub> 120 dB 50 dB Smart Smoothing

- a. For max. measuring span

**Material, Pressure Rating & Contact Face, Mounting Direction**

see Model Codes

Material Amplifier housing	Aluminum (Alloy No. GD-Al Si 12), Polyurethan coated, or Stainless Steel
<b>For Sour Gas applications according to NACE Standard MR-0175 and MR-0103:</b>	
Wafer body	316L (1.4404)
Torque tube (a)	Hastelloy C or Inconel 600

- a. The material of the seal at the Torque tube bearing corresponds to the material of the head piece.

**Mounting**

Mounting method	sandwich mounted
▶ according to DIN	DN 80, DN 100
▶ according to ANSI	3 inch, 4 inch

**NOTE**

Always follow the RH or LH version as shown in Figure 5. The device can not be used "upside down". All internal parts are mounted and calibrated in inverse manner. The conversion can be performed only by the manufacturer or a contractual partner. Otherwise calibration and pressure test are invalid.

**Weight**

Transmitter	see "MODEL CODES 244LD LEVELSTAR"
Displacer	see "MODEL CODES 244LD LEVELSTAR"

**Electrical Connection**

Cable entry thread	M20x1.5 or 1/2-14 NPT
Screw terminals	wire cross-section up to 2.5 mm <sup>2</sup>
Test sockets	Ø 2 mm

**NOTE**

Cable gland and screwed sealing plug have to be ordered separately under model code BUSG.

For equipment in Ex d version, 1 screwed sealing plug made of stainless steel is included in delivery.

**Electromagnetic Compatibility EMC**

Operating Conditions	Industrial Environment
Immunity according to EN 61326-1:2013-07	fulfilled
Emission according to ▶ EN 61326-1:2013-07 ▶ EN 55011:2018-05, Group 1, Class A	fulfilled
NAMUR recommendation NE 21 Status Aug. 2017	fulfilled

**SAFETY REQUIREMENTS**

For more information about Safety Operating Instructions, see MI EML0010A-Ex.

**CE Label**

Electromagnetic compatibility	2014/30/EU fulfilled
Explosion protection according to ATEX	2014/34/EU
RoHS2 (a)	2011/65/EU

a. RoHS and REACH compliance documents for the 244LD can be downloaded from <https://checkaproduct.se.com/>

**Safety**

According to EN 61010-1 (resp. IEC 1010-1)	safety class III
Internal fuses	none
External fuses	Limitation of power supplies for fire protection have to be observed due to EN 61010-1, appendix F (resp. IEC 1010-1).

244LD LEVELSTAR VERSIONS

Figure 5. 244LD LevelStar Versions

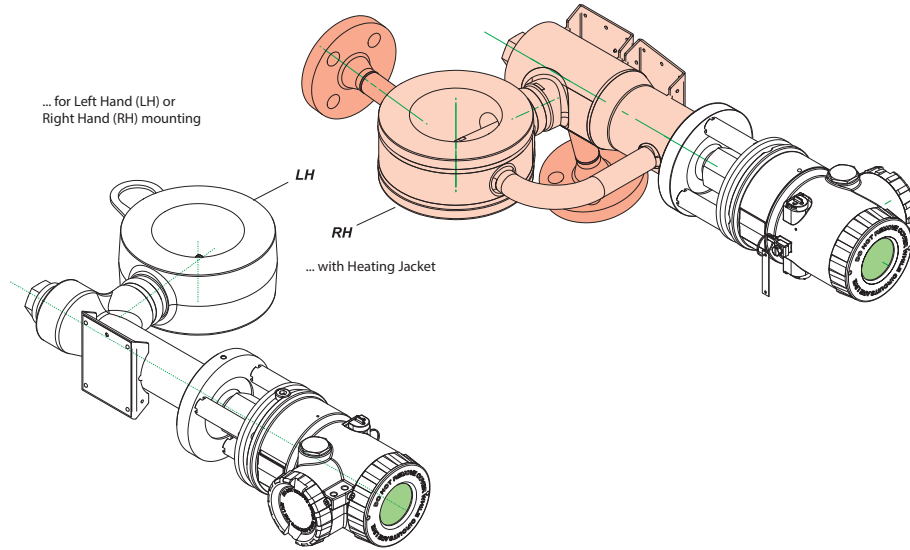

ELECTRICAL CLASSIFICATION ATEX

With appropriate order only.

National requirements have to be observed.

**Intrinsic Safe:**

AID 421	II 1/2 G Ex d ib/ia IIB/IIC T4/T6 Ga/Gb	PTB 04 ATEX 2011X	Zone 0
AID 421	II 2 G Ex d ib/ia IIB/IIC T4/T6 Ga/Gb	PTB 04 ATEX 2011X	Zone 1

**Explosion-proof:**

AD 432 A	II 1/2 G Ex d IIC T4/T6 Ga/Gb	PTB 02 ATEX 1025 X	Zone 0
AD 432 B	II 1/2 G Ex d IIC T4/T6 Ga/Gb	PTB 02 ATEX 1025 X	Zone 1
AD 432	II 2 G Ex d IIC T4/T6 Gb		

**Zone 2:**

Manufacturer's Declaration

Version with Heating Jacket

Figure 6. Sandwich-mounted between displacer chamber 204DC and cover flange 204BCF, with displacer 204DE

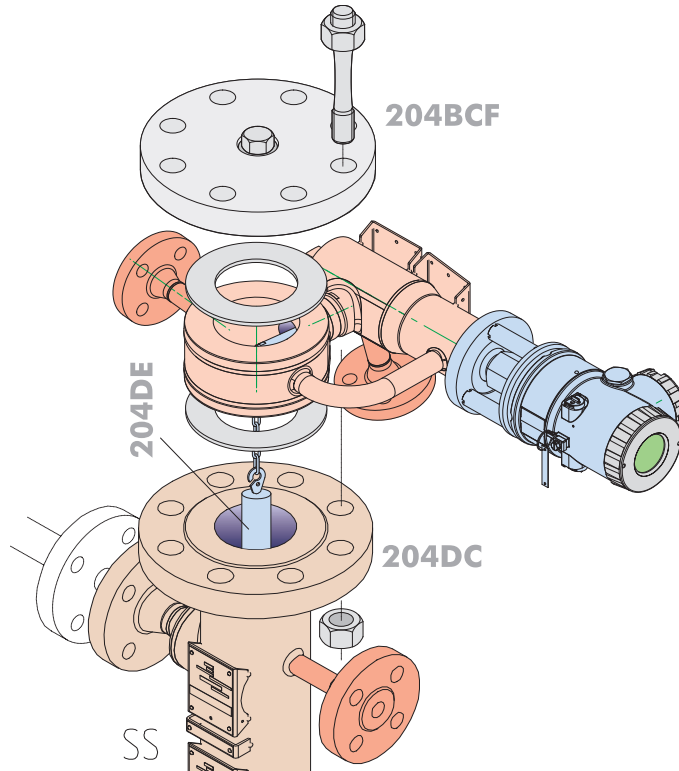

Comparison of Material

Code	WNR	DIN	Remarks	Equivalent to
P235G1TH P235GH	1.0305 1.0345	EN 10 216-2	VdTÜV - Wbl. 457	ASTM A 106 A
P250GH	1.0460	EN 10 273	VdTÜV - Wbl. 350/3	ASTM A 105
X6 CrNiMoTi 17 12 2	1.4571	DIN EN 10088-3	VdTÜV - Wbl. 411	ASTM 316Ti
X2 CrNiMo 17 13 2	1.4404		VdTÜV - Wbl. 411	ASTM 316L
X2 CrNiMo 18 14 3	1.4435		VdTÜV - Wbl. 411	
X3 CrNiMo 17 13 3	1.4436		VdTÜV - Wbl. 411	
NiMo 16 Cr 15 W	2.4819	17 744	equal to Hastelloy C276 VdTÜV - Wbl. 400	UNS N10276
NiCr 15 Fe	2.4816	17 742	Inconel 600 VdTÜV - Wbl. 305	UNS N06600
NiCr 22 Mo 9 Nb	2.4856	17 744	Inconel 625 VdTÜV 499	UNS N06625
NiCr 21 Mo	2.4858	17 744	Inconel 825 VdTÜV 432	UNS N08825
X 2 CrNiMo 22 5 3	1.4462	EN 10222-5	Duplex VdTÜV 418	UNS S31803
GD - AlSi 12	3.2582.05	17 007	Al - Die-casting	



### Service Limits of Wafer Body PN 250 made of (material)

Max. operating pressure in bar at temperature in °C

#### 1.0460

°C	-10 to 120	200	250	300	350		
bar	250	200	175	150	140	DIN	
bar	231	219	206	180	145	ANSI	

1.4404 / 1.4435 / 1.4571

°C	-196 to -10	-10 ... +50	100	200	300	400	500	
bar	250	250	230	200	177	162	148	DIN
bar	248	248	211	178	158	145	138	ANSI

1.4462

°C	-10 to 50	100	150	200	250	280		
bar	250	225	209	194	184	178	DIN	
bar	260	234	218	201	191	185	ANSI	

Inconel 625

°C	-196 to 50	100	200	300	400	450		
bar	250	230	210	197	184	177	DIN	
bar	255	234	214	201	187	181	ANSI	

Inconel 825

°C	-10 to 50	100	200	300	400	450		
bar	250	216	187	176	164	159	DIN	
bar	260	224	195	183	171	165	ANSI	

Hastelloy C (2.4610 / 2.4819 / 2.4602)

°C	-196 to -10	50	100	200	300	400		
bar	250	250	233	209	200	184	DIN	
bar	260	260	243	217	209	192	ANSI	

#### Table of Weights

Transmitter	Weight [kg]					
	DIN PN		ANSI Class			
	16 to 160	250	150	300 / 600	900	1500
DN 80 / 3 inch	12.5	12.5	12.5			16
DN 100 / 4 inch	13.5	13.5	13.5			18.5

MODEL CODES 244LD LEVELSTAR

<u>Intelligent Buoyancy Transmitter with Torque Tube</u>	<u>244LD</u>
<b><u>Wafer Body Material (Process wetted):</u></b>	
1.0460 (~A 105 Carbon Steel), application from -10°C to 350°C	-K
1.4404 (316L) or 1.4435 if Pressure Rating codes H1 and H2 are selected, application from -60°C to 400°C	-S
1.4404 (316L) or 1.4435 if Pressure Rating codes H1 and H2 are selected, application from -196°C to 400°C	-U
1.4404 (316L) or 1.4435 if Pressure Rating codes H1 and H2 are selected, application from -60°C to 500°C	-T
1.4541 (321), application from -60°C to 400°C	-H
1.4462 (Duplex), application from -10°C to 280°C	-N
2.4856 (Inconel 625), application from -196°C to 450°C	-R
2.4819 (Hastelloy C/276), appl. from -196°C to 400°C	-C
<b><u>Torque Tube Material (Process wetted):</u></b>	
1.4404 (316L)	S
Hastelloy C/276	X
2.4816 (Inconel 600)	I
2.4375 (Monel K500)	M
<b><u>Wafer Body Flange Size (Nominal size):</u></b>	
DN 70 (available with Wafer Body Material S, U, T, and Torque Tube Material S and X)	0
DN 80	1
DN 100	2
3 inch	3
4 inch	4
<b><u>Wafer Body Pressure Rating &amp; Contact Face</u></b>	
PN40 (PN16 to PN40) B1/B1 according to DIN EN 1092-1	B1
PN250 (PN16 to PN250) B2/B2 according to DIN EN 1092-1 (a)	B2
PN250 (PN16 to PN250) D/C (Groove Face / Tongue Face according to DIN EN 1092-1) (a) (b)	DC
PN250 (PN16 to PN250) D/D (Groove Face / Groove Face according to DIN EN 1092-1) (a)	DD
PN250 (PN16 to PN250) F/F (Recess Face / Recess Face according to DIN EN 1092-1) (a)	FF
PN250 (PN16 to PN250) F/E (Recess Face / Spigot Face according to DIN EN 1092-1) (a) (c)	FE
PN250 (PN16 to PN250) L/L (Lens Face / Lens Face according to DIN 2696) (a)	L1
PN400 L/L Lense (Lens Face / Lens Face according to DIN 2696) (d) (e)	H1
PN500 L/L Lense (Lens Face / Lens Face according to IG-Norm High Pressure Version) (e) (f)	H2
ANSI Class 150 RF/RF (Raised Face / Raised Face) (g)	R1
ANSI Class 900 (300/600/900) RF/RF (Raised Face / Raised Face) (g)	R2
ANSI Class 1500 RF/RF (Raised Face / Raised Face) (g)	R3
ANSI Class 150 SF/SF (Smooth Finish / Smooth Finish) (g)	S1
ANSI Class 900 (300/600/900) SF/SF (Smooth Finish/Smooth Finish) (g)	S2
ANSI Class 1500 SF/SF (Smooth Finish / Smooth Finish) (g)	S3
ANSI Class 150 RJF/RJF (g)	J1
ANSI Class 900 (300/600/900) RJF/RJF (g)	J2
ANSI Class 1500 RJF/RJF (g)	J3
ANSI Class 300 to 1500, LF/LM (Large Female / Large Male) (g)	LM
ANSI Class 300 to 1500, LF/LF (Large Female / Large Female) (g)	LF
ANSI Class 300 to 1500, LG/LT (Large Groove / Large Tongue) (g)	LT
ANSI Class 300 to 1500, LG/LG (Large Groove / Large Groove) (g)	LG
ANSI Class 150, SG/ST (Small Groove / Small Tongue) (g)	GT
ANSI Class 300 to 1500, SG/ST (Small Groove / Small Tongue) (g)	ST
ANSI Class 150, SG/SG (Small Groove / Small Groove) (g)	GG
ANSI Class 300 to 1500, SG/SG (Small Groove / Small Groove) (g)	SG
<b><u>Wafer Body Mounting Direction: (Amplifier to body)</u></b>	
Right Hand Mounted	R
Right Hand Mounted with heating jacket:	
connecting flanges B1 / DN15, PN40 (DIN EN 1092-1) (h) (i) (j)	A
connecting flanges B1 / DN25, PN40 (DIN EN 1092-1) (h) (i) (j)	B
connecting flanges B2 / DN15, PN40 (DIN EN 1092-1) (h) (i) (i)	C

MODEL CODES 244LD LEVELSTAR

Intelligent Buoyancy Transmitter with Torque Tube	244LD
connecting flanges B2 / DN25, PN40 (DIN EN 1092-1) (h) (i) (j)	D
connecting flanges RF/SF, 1/2 inch, Class 300 (h) (i) (j)	E
connecting flanges RF/SF, 1 inch, Class 300 (h) (i) (j)	F
connecting flanges RJF, 1/2 inch, Class 300 (h) (i) (j)	G
connecting flanges RJF, 1 inch, Class 300 (h) (i) (j)	H
Left Hand Mounted	L
<b>Version:</b>	
Base VERSION - LEVELSTAR - (244LD) (k) (l)	N
<b>Cable Entry:</b>	
M20x1.5 without cable gland	M
1/2-14 NPT without cable gland	N
<b>Communication:</b>	
HART®	H
FOUNDATION Fieldbus H1 (m)	B
<b>Electrical Classification:</b>	
ATEX intrinsic safe Zone 0, IIC T4 (HART®) (n)	0C4
ATEX intrinsic safe Zone 0, IIC T6 (HART® or FOUNDATION Fieldbus) (n)	0C6
ATEX intrinsic safe Zone 1, IIC T4 (HART®)	1C4
ATEX intrinsic safe Zone 1, IIC T6 (HART® or FOUNDATION Fieldbus)	1C6
ATEX intrinsic safe Zone 2, IIC T4 (HART®)	2C4
ATEX intrinsic safe Zone 2, IIC T6 (HART® or FOUNDATION Fieldbus)	2C6
ATEX explosionproof Zone 0, IIC T6	D0C
ATEX explosionproof Zone 1, IIC T6 (n)	D1C
FM Explosionproof	FDZ
CSA Explosionproof	CDZ
EAC Intrinsically Safe Zone 0 - IIC T6 (j)	GA0
EAC Intrinsically Safe Zone 1 - IIC T6	GA1
EAC Explosionproof Zone 1 - IIC T6	GD1
NEPSI Intrinsically Safe, Ex d ia IIB/IIC T4/T6 Ga/Gb or Ex d ia IIB/IIC T4/T6 Gb	NA6
NEPSI Explosionproof, Ex d IIB/IIC T4/T6 Gb	NDZ
BRAZIL Intrinsically Safe, Ex d ib/ia IIC T6/T4 Gb/Ga	BA6
For General Purpose Areas; without certification	ZZZ
<b>Options:</b>	
Housing Complete Stainless Steel	H
External Pushbuttons for Maintenance (o)	M
<b>Tag No. Labeling</b>	
Stainless Steel Label Fixed with Wire	L
<b>Certificates</b>	
EN 10204-2.1, Certificate of Compliance	1
EN 10204-2.2, Specific Test Report (Calibration)	2
EN 10204-3.1, Inspection Certificate of Process Wetted Material (for wafer body only)	3
PED 2014/68/EU additional unit verification, according to module F/G	4
EN 10204-2.2, Specific Test Report (Pressure Test)	P
Comply with NACE Standard MR0175 not with Wafer Material K (Carbon Steel) and not with Torque Tube	
Material S (Stainless Steel)	6
Comply with NACE Standard MR0103 not with Wafer Material K (Carbon Steel) and not with Torque Tube	
Material S (Stainless Steel)	I
SIL 2 Certificate (p)	Q
<b>Material Test</b>	
X-Ray or Isotope Test for Weldings	7
Dye Penetration Test	8
PMI -Test	5

MODEL CODES 244LD LEVELSTAR

Intelligent Buoyancy Transmitter with Torque Tube	244LD
<p><b>Subassemblies</b>                      TRANSSTAR-housing with LEVELSTAR-electronic for selected code (244LD-*****-N) (q)                      Torque Tube for selected code (244LD-*****-W) (r)                      Amplifier for selected code (244LD-*****-X) (s)                      Complete Sensor for selected code (244LD-*****-Y) (t)</p>	<p>N W X Y</p>

- a. Available with Wafer Body Flange Size 1 or 2.
- b. D at top.
- c. F at top.
- d. Available with Wafer Body Flange Size 1.
- e. Available with Wafer Body Material codes S, U, T, or Torque Tube Material codes S, C.
- f. Available with Wafer Body Flange Size 0.
- g. Available with Wafer Body Flange Size 3 or 4.
- h. Wafer Body Flange Size code 3 available only with Wafer Body Pressure Rating code R2, S2, J2; Wafer Body Flange Size code 4 available only with Wafer Body Pressure Rating code R1, S1, J1, GT, GG.
- i. Available with Wafer Body Material codes S, U, T.
- j. Not with Pressure Rating H1 or H2.
- k. Only with Communication H (HART®) and electrical Classification 0C6, 1C6, D0C, D1C, 2C6.
- l. Electrical Classification FDZ, CDZ, GA6, GDZ, NA6, NDZ, BA6, BDZ.
- m. LevelStar with Electrical Classification D1C, D0C, 1C6, 0C6, 2C6, ZZZ.
- n. Not available with Wafer Body Pressure Rating & Contact Face codes L1, J1, J2, J3, H1, H2, DD.
- o. Not with Optionals -H and Version B, S or C.
- p. Only available with HART® Communication.
- q. Not with (Optional features: M, R, B, V, 9, K, A, G, 2, 3, 4, 6, Q, 7, 8, 5, W, X, Y, or Z).
- r. Not with (Optional feature H, R, B, L, F, V, 9, K, A, G, 2, 4, Q, X, Y, or Z).
- s. Not with (Optional feature H, R, B, V, 9, K, A, G, 2, 3, 4, 6, Q, 7, 8, 5, W, Y, or Z).
- t. Not with (Optional feature H, R, B, L, F, V, 9, K, A, G, 2, Q, 7, 8, 5, W, X, or Z).

## DISPLACER 204DE

Table 1. Typical Dimensions and Weights for Density Ranges  $\Delta\rho$  (a)

Material	316L (1.4404 / 1.4435) (b)												PTFE /PTFE with 25% C				Hastelloy C276					
Code	-S (PN 100)				-T (c)(PN 40 / 63)				-S (PN 250)				-S (PN 500)				-S (PN 100 / 160)					
Density Range $\Delta\rho$																						
250 to 1500 kg/m <sup>3</sup>					300 to 600 kg/m <sup>3</sup>					400 to 2000 kg/m <sup>3</sup>				200 to 1500 kg/m <sup>3</sup>				300 to 1500 kg/m <sup>3</sup>				
Len. L	$\phi$ mm	Vol. cm <sup>3</sup>	Wei. N	PN bar	$\phi$ mm	Vol. cm <sup>3</sup>	Wei. N	PN bar	$\rho_{\min}^{(d)}$ kg/m <sup>3</sup>	$\phi$ mm	Vol. cm <sup>3</sup>	Wei. N	PN bar	$\phi$ mm	Vol. cm <sup>3</sup>	Wei. N	PN bar	$\phi$ mm	Vol. cm <sup>3</sup>	Wei. N	PN bar	
mm																						
350	60.3	1000	19	100	101.6	2840	38	40	460	42.4	500	18	250	62	1056	23	500	60.3	1000	18	100	
500	48.3	920	17	100	88.9	3100	43	63	580	42.4	710	24	250	51	1021	23	500	48.3	920	19	100	
750	42.2	1060	21	100	76.1	3410	44	63	545	33.7	670	21	250	42	1039	24	500	48.3	1370	27	100	
1000	33.7	890	17	100	60.3	2855	41	63	545	26.9	570	18	250	35	961	21	500	33.7	890	19	100	
1200	33.7	1070	20	100	60.3	3425	48	63	675	26.9	680	22	250	35	1153	25	500	33.7	1070	22	100	
1500	26.9	850	16	100	51	3065	39	63	460	21.3	540	17	250	30	1060	24	500	26.9	850	18	160	
1800	26.9	1020	19	100	42.4	2540	38	63	495	21.3	640	20	250	28	1107	25	500	26.9	1020	21	160	
2000	26.9	1140	21	100	42.4	2825	41	63	565	21.3	710	22	250	25	981	22	500	26.9	1140	23	160	
2500	21.3	890	20	100	38	2840	37	63	425	17.2	580	16	250	22.5	993	23	500	21.3	890	23	160	
3000	21.3	1070	24	100	38	3400	45	63	575	17.2	700	23	250	20	942	22	500	21.3	1070	27	160	
inch																						
14	60.3	1020	20	100	101.6	2885	38	40	455	42.4	510	18	250	62	1074	23	500	60.3	1020	18	100	
32	42.4	1150	23	100	76.1	3700	47	63	595	33.7	730	23	250	42	1126	26	500	33.7	720	16	100	
48	33.7	1090	20	100	60.3	3480	49	63	680	26.9	690	22	250	35	1171	26	500	33.7	1090	23	100	
60	26.9	870	16	100	51	3115	40	63	465	21.3	540	18	250	30	1076	24	500	26.9	870	18	100	
72	26.9	1040	19	100	42.4	2580	38	63	505	21.3	650	21	250	28	1124	26	500	26.9	1040	21	160	
84	26.9	1210	22	100	42.4	3000	44	63	635	21.3	760	23	250	25	1046	24	500	26.9	1020	25	160	
96	21.3	870	20	100	38	2765	37	63	420	17.2	570	16	250	22.5	968	22	500	21.3	870	23	160	
120	21.3	1090	25	100	38	3455	46	63	595	17.2	710	24	250	20	957	22	500	21.3	1090	25	160	

- a.  $\Delta\rho = \rho_1 - \rho_2$ ;  $\rho_1$  = density of lower medium,  $\rho_2$  = density of upper medium  
b. Using displacer material 1.4571 can cause small deviations in diameter, volume and weight.  
c. For measurement of interface or density, the max. density of the lower medium is 1350 kg/m<sup>3</sup>.  
d. Min. density of the lower medium.

If a Displacer Chamber is used, the difference between the diameter of the Displacer and the inside diameter of the Displacer Chamber must be at least 10 mm.

Lengths < 350 mm and > 3000 mm, and density ranges < 300 kg/m<sup>3</sup> and > 2000 kg/m<sup>3</sup> on request.

### Accessories

For Displacer Chamber 204DC, Flange combination 204FK and Cover Flange Kit 204BCF, see PSS EML0901, 204xx Accessories for Buoyancy Transmitter.

Figure 7. 204xx Accessories for Buoyancy Transmitter

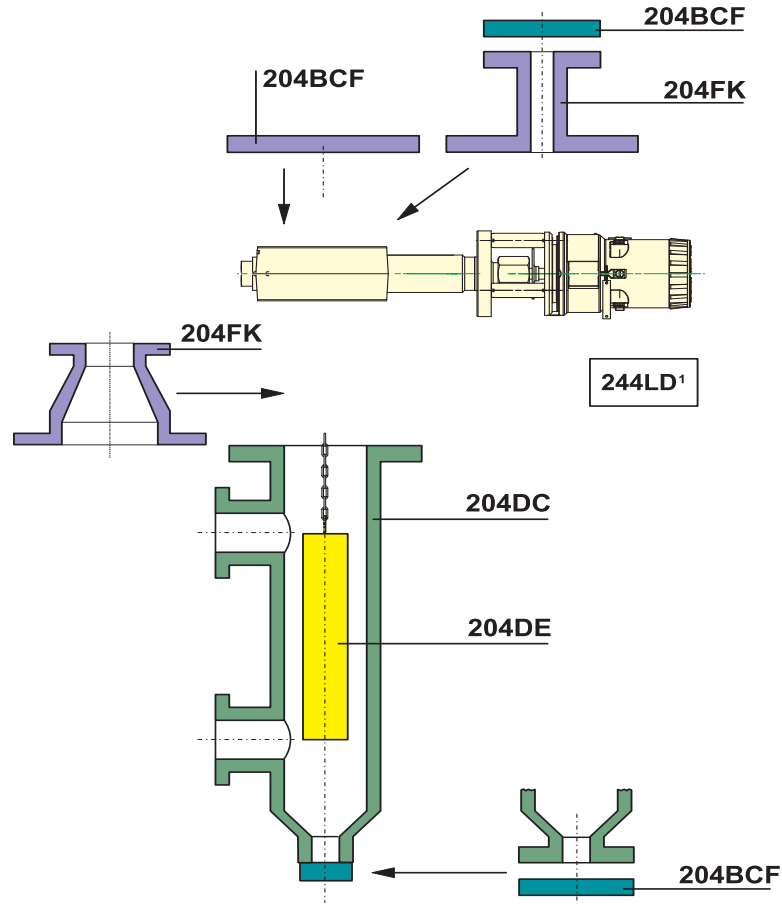

MODEL CODES 204DE

<b>Displacer for Buoyancy Transmitters from 2 N buoyancy up to 20 N 204DE</b>	
<b>Range Of Application (a)</b>	
Liquid Level - Media: Liquid / Gas or Air (Density difference = 250 kg/m <sup>3</sup> to 2000 kg/m <sup>3</sup> ) (= 9x10 <sup>-3</sup> lbm/in <sup>3</sup> to 72.2x10 <sup>-3</sup> lbm/in <sup>3</sup> )	-S
Interface Level / Density - Media: Liquid 1 / Liquid 2 (Density difference = 300 kg/m <sup>3</sup> to 600 kg/m <sup>3</sup> ) (= 10.8x10 <sup>-3</sup> lbm/in <sup>3</sup> to 22.7x10 <sup>-3</sup> lbm/in <sup>3</sup> ) (b)	-T
<b>Displacer Material</b>	
1.4404 (316L)	S
1.4541 (321)	H
PTFE (not for applications in Zone 0)	P
PTFE with 25% Carbon, for Zone 0	O
Hastelloy C/276	X
2.4856 (Inconel 625) (c)	R
2.4360 (Monel 400) (c)	M
3.7035 (Titan)	T
<b>Pressure Rating</b>	
Up to PN 100 / Class 600	D
Up to PN 160 / Class 900	E
Up to PN 250 / Class 1500	F
Up to PN 500 / Class 2500	G
<b>Suitable for Flange Size (at top of vessel / chamber)</b>	
DN 50	0
DN 70	1
DN 80	2
DN 100	3
DN 150	4
2 inch	5
3 inch	6
4 inch	7
6 inch	8
<b>Displacer Length "L": (inches are approx.)</b>	
<b>for Displacer Material codes P, and O:</b>	
300 mm (12 inch) to 2000 mm (79 inch), with partition > 1000 mm	A
2001 mm (79 inch) to 4000 mm (157 inch), with partition points	B
4001 mm (157 inch) to 6000 mm (236 inch), with partition points	C
6001 mm (236 inch) to 8000 mm (315 inch), with partition points	D
8001 mm (315 inch) to 10000 mm (394 inch), with partition points	E
10001 mm (394 in) to 12000 mm (472 in), with partition points	F
<b>for Displacer Material codes S, H, C, R, M, and T:</b>	
300 mm (12 in) to 3000 mm (118 in) without partitioning	K
3001 mm (118 in) to 6000 mm (236 in) One partition point	L
6001 mm (236 in) to 9000 mm (354 in) Two partition points	M
9001 mm (354 in) to 12000 mm (472 in) Three partition points	N
12001 mm (472 in) to 15000 mm (591 in) Four partition points	O
<b>Material and Length of the Suspension (Length "b") (d)</b>	
1.4404 (316L) Standard length of Suspension (e)	S1
1.4404 (316L) Customized Suspension Length (f)	S2
1.4541 (321) Standard length of Suspension (e)	H1
1.4541 (321) Customized Suspension Length (f)	H2
Hastelloy C / Standard length of Suspension (e)	C1
Hastelloy C / Customized Suspension Length (f)	C2
2.4856 (Inconel 625) / Standard length of Suspension (e)	I1
2.4856 (Inconel 625) / Customized Suspension Length (f)	I2

MODEL CODES 204DE

<b>Displacer for Buoyancy Transmitters from 2 N buoyancy up to 20 N 204DE</b>	
2.4360 (Monel 400) / Standard length of Suspension (e)	M1
2.4360 (Monel 400) / Customized Suspension Length (f)	M2
3.7035 (Titan) / Standard length of Suspension (e)	T1
3.7035 (Titan) / Customized Suspension Length (f)	T2
<b>Options</b>	
For application in Zone 0 (Additional grounding rope) (not available with Displacer Material: P)	-E
Damping Spring (Mat. 1.4310, max. 250°C (482°F))	-D
Damping Spring (Mat. HC, max 350°C (662°F))	-C
Tag No. Labeling – Stainless Steel Label Fixed with Wire (Text required)	-L
Density difference > 200 kg/m <sup>3</sup> ; < 300 kg/m <sup>3</sup> (a)	-Y
Density difference < 200 kg/m <sup>3</sup> (a)	-Z
<b>Certificates</b>	
EN 10204-2.1 Certificate of Compliance	-1
EN 10204-3.1 Inspection Certificate of Process Wetted Metallic Material (not available with Displacer Material: P and O)	-3
PMI - Test (not available with Displacer Material: P and O)	-5

- a. Upper and Lower Medium Density required (at operating temperature).
- b. Consult TCO if pressure rating is F or G.
- c. On ECEP request.
- d. +/- 8 mm (+/- 0.3 inch).
- e. Only in connection with Model Code 204DC.
- f. Exact length required (Contact face of flange to upper end of displacer).



**Table of Versions**

for Dimensions c, d, g, see Figure 8.

**Table 2. Versions for Dimensions c, d, g**

Version		Form of Sealings	DN 80 / 3 inch			DN 100 / 4 inch				
PN			c	d	g	c	d	g		
DIN EN	16	B1 DIN EN 1092	140	82	140	160	102	162		
	40									
	63	B2 / C / D / F / E DIN EN 1092								
	100	Form L DIN 2696								
	160									
	250									
ANSI	150	RF / SG / ST ANSI B16.5	140	82	140	160	102	162		
	300									
	600									
	900									
	1500									
	150	RJF ANSI B16.5	140	82	140	160	102	174		
	300				147					
	600				102				162	206
	900									
	1500									
	300	LF / LM / LG / LT ANSI B16.5	140	82	140	160	102	174		
	600									
	900									
	1500									

- ▶ RF - Raised Face
- ▶ RJF - Ring Joint Face
- ▶ LF - Large Female
- ▶ LM - Large Male
- ▶ LG - Large Groove
- ▶ LT - Large Tongue
- ▶ SG - Small Groove
- ▶ ST - Small Tongue

DIMENSIONS

Figure 8. 244LD up to PN 250 / Class 1500

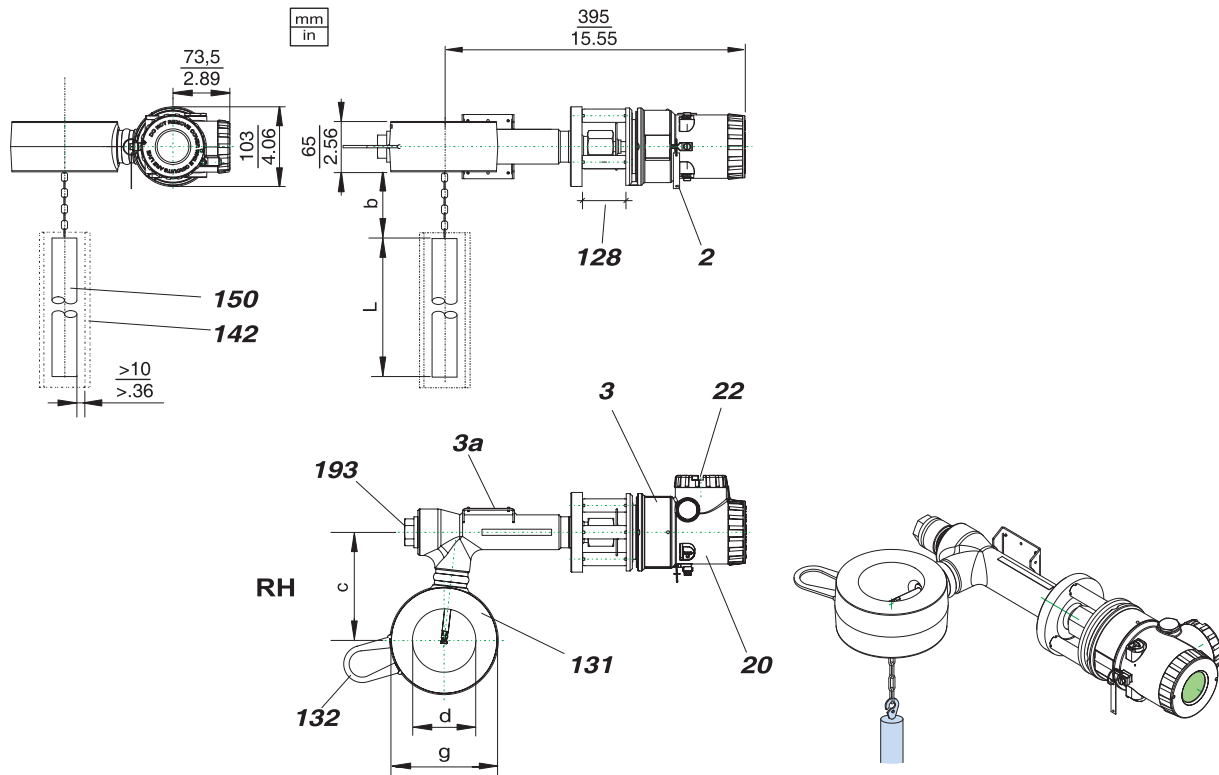

- 2 Name Plate
- 3 Data label
- 20 Amplifier housing
- 22 Connection compartment
- 128 Heat sink
- 131 Wafer body
- 132 Lifting hook
- 142 Protective tube for displacer
- 150 Displacer
- 193 Lock screw

**LH Left hand** = mounting amplifier to wafer body "Left hand mounted" (Model Code L)  
**RH Right Hand** = mounting amplifier to wafer body "Right hand mounted" (Model Code R)

The above mentioned RH dimensions are also for LH. Dimensions c, d and g, see Table 2.

See MI EML0710 for information on heating jacket.

NOTES

## ORDERING INSTRUCTIONS

1. Model Number
2. Electrical Safety Design Code
3. Accessories
4. User Tag Information

## ADDITIONAL PRODUCTS

These product lines offer a broad range of measurement and instrument products, including solutions for pressure, flow, analytical, temperature, positioning, and controlling.

For a list of these offerings, visit our web site at:

[www.se.com](http://www.se.com)

Schneider Electric Systems USA, Inc. Global Customer Support  
70 Mechanic Street Inside U.S.: 1-866-746-6477  
Foxboro, MA 02035 Outside U.S.: 1-508-549-2424  
United States of America <https://pasupport.schneider-electric.com>  
<http://www.se.com>

Copyright 2016-2022 Schneider Electric Systems USA, Inc. All rights reserved.

The Schneider Electric brand and any trademarks of Schneider Electric SE or its subsidiaries are the property of Schneider Electric SE or its subsidiaries. All other trademarks are the property of their respective owners.

