

PSC-CS-Laser-LT

Digital 2-wire, Self-Contained IR thermometer with Precision Dual Laser targeting from -30°C to 1000°C (-22°F to 1832°F)



FEATURES

- Fast, high accuracy and small spot size
- Optical resolution up to 50:1 with selectable optics
- Double laser aiming identifies real spot location and actual spot size at any distance
- Scalable 4-20 mA output in combination with simultaneous alarm output
- USB programming interface and software - optional
- On board emissivity adjustment or remote via software
- Short circuit and polarity reversal protection
- Usable up to 85°C ambient temperature without cooling
- Automatic laser switch off at 50°C
- Wide power requirement range: 5 to 28 V DC

General Specifications

Environmental rating	IP 65 (NEMA-4)
Ambient temperature	-20 - 85°C (50°C with laser on)
Storage temperature	-40 - 85°C
Relative humidity	10 - 95 %, non condensing
Vibration	IEC 68-2-6: 3 G, 11-200 Hz, any axis
Shock	IEC 68-2-27: 50 G, 11 ms, any axis
Weight	600 g

Electrical Specifications

Output/analog	4 - 20 mA
Loop resistance	max. 1000 Ω ¹⁾
Output/ alarm	0-30 V/ 500mA (open collector)
Output/ digital	uni-/ bidirectional, 9.6 kBaud, 0/3 V digital level, USB optional
Cable length (connector version only)	3 m/ 8 m/ 15 m
Current draw (laser)	45mA @ 5V 20mA @ 12V 12mA @ 24V
Power supply	5 - 28 V DC

¹⁾ in dependence on supply voltage

Measurement Specifications

Temperature range (scalable via software)	(LT) -30 to 1000°C/-22 to 1832°F
Spectral range / model	8 - 14 μm / PSC-CS Laser-LT
Optical resolution	50:1
System accuracy (at ambient temperature 23 ± 5°C)	± 1% or ± 1°C ¹⁾
Repeatability (at ambient temperature 23 ± 5°C)	± 0.5% or ± 0.5°C ¹⁾
Temperature resolution (digital)	0.1 K
Response time (90% signal)	150 ms
Emissivity/ Gain (adjustable via switches or via software)	0.100 - 1.100
IR window correction (adjustable via software)	0.100 - 1.000
Signal processing (parameter adjustable via software)	peak hold, valley hold, average; extended hold function with threshold and hysteresis

¹⁾ whichever is greater

PSC-CS-Laser-LT

Optical Specifications

LT optics

...SF	24 mm@ 1200 mm
...CF1	1.4 mm@ 70 mm
...CF2	3 mm@ 150 mm
...CF3	4 mm@ 200 mm
...CF4	9 mm@ 450 mm

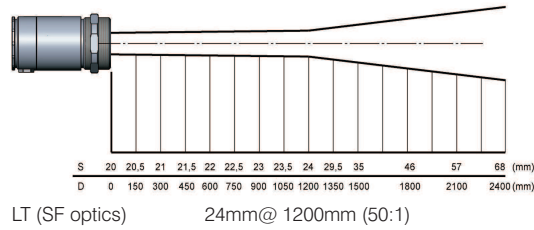

Analog mode: 4-20mA

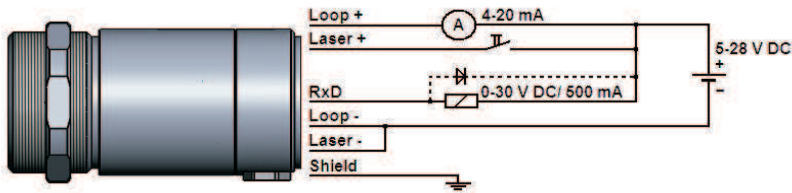

Programming mode: USB

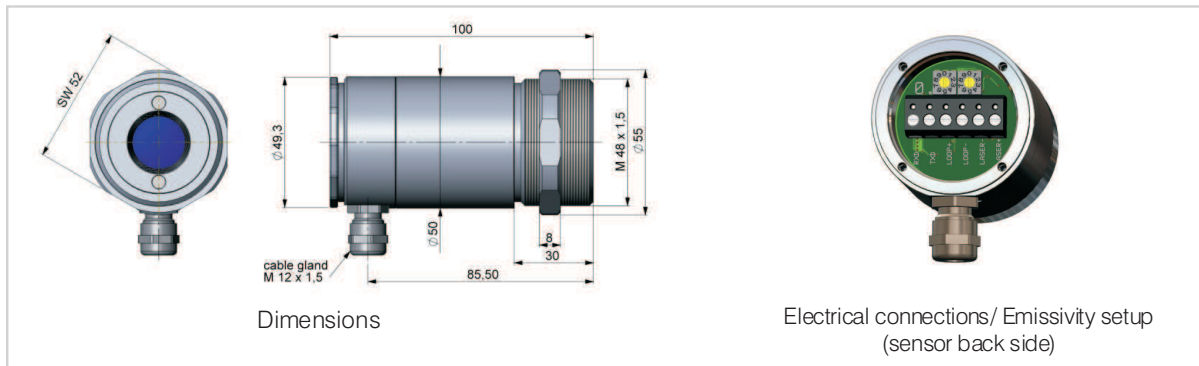
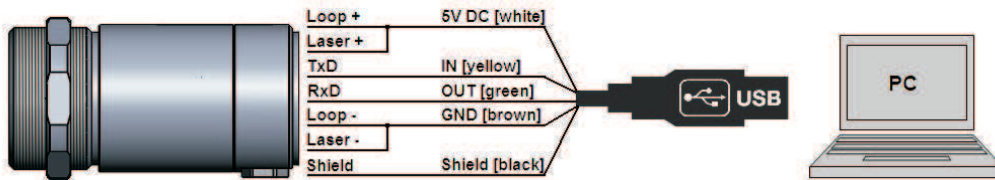

PSC Connect Software

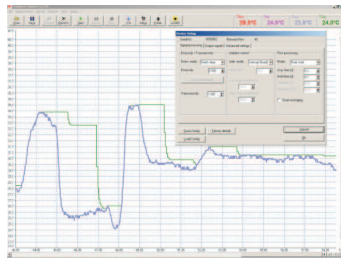

- Software for easy sensor setup and remote controlling, supports multi tasking
- Graphic display for temperature trends and automatic data logging for analysis and documentation with 1 ms response time
- Adjustment of signal processing functions and programming of the sensor outputs
- The software PSC Connect allows to customize the sensor to application needs of the user