

Models CFS10 and CFS20 Mass Flowtubes for Standard and 3-A Sanitary Applications



The Foxboro® CFS10 and CFS20 Mass Flowtubes combine with a Model CFT50 or CFT51 Digital Coriolis Mass Flow Transmitter to form a Foxboro Coriolis Mass Flow and Density Meter. The principle of Coriolis acceleration is used which allows true mass flow rate measurements of fluids to be made directly, without the need for external temperature, pressure, or specific gravity measurements.

FEATURES

- ▶ Precision system achieved using digital signal processing (DSP) transmitter.
- ▶ High system accuracy of $\pm 0.10\%$ of flow rate plus flowtube zero instability (liquids); $\pm 0.50\%$ of flowrate plus flowtube zero instability (gases).
- ▶ Density accuracy of ± 0.0005 g/cc or better.
- ▶ Wide rangeability in excess of 100:1 without sacrificing performance.
- ▶ Complies with 3-A sanitary standards.
- ▶ The CFS10 single path design ideal for shear sensitive fluids, and in applications requiring positive cleaning; available in 3 to 50 mm (1/8 to 2 in) sizes. The CFS20 is a dual path design and is available in 40 and 80 mm (1 1/2 and 3 in) sizes.
- ▶ Welded 304 ss stainless steel enclosure. Hermetically sealed with 70 kPa (10.15 psia) internal pressure.
- ▶ Thick-wall nickel alloy (equivalent to Hastelloy® C-22(1)) construction available.
- ▶ Weights and Measures Custody Transfer option, per NIST Handbook 44.
- ▶ Weights and Measures Industry Canada Approval option.
- ▶ Tamperproof Sealing option of terminal block cover provided with Options -T, -D, and -S.
- ▶ Patented anti-phase double driver system allows close sensor proximity to inhibit signal distortion, and provides low power consumption per driver.
- ▶ Low stress levels maximize mechanical reliability.
- ▶ Easy installation with short end-to-end distance.
- ▶ Will drain when mounted in vertical orientation with an upward flow.
- ▶ Uses tubes essentially of same nominal I.D. as connecting pipe, and with increased wall thickness.
- ▶ Designed for FM, CSA, and ATEX hazardous area locations. Applicable agency plate also includes the CE mark.

1. Hastelloy is a registered trademark of Haynes International Inc.

INTRODUCTION

This Mass Flow and Density Meter, comprising a CFT51 Mass Flow and Density Transmitter and a CFS10 or CFS20 Mass Flowtube, measures fluid mass flow rate directly, not inferentially. The direct measurement of mass eliminates the inaccuracies of multiple process measurements associated with volumetric flow devices are eliminated.

This flowmeter is an advanced generation of mass flow devices using Coriolis principles. It incorporates significant improvements in transmitter and flowtube design, including digital signal processing (DSP), computer modeling, remote communications, automated manufacturing processes, construction and testing that all add up to an ideal product for today and tomorrow's "real world" process fluid flow applications.

MODEL CFT50/CFT51 DSP TRANSMITTER

The CFS10 and CFS20 Mass Flowtubes are used with the Model CFT50/CFT51 Digital Coriolis Mass Flow Transmitter to form a mass flow and density meter. The transmitter uses DSP techniques to improve flowmeter performance and to minimize the shortcomings experienced by existing Coriolis flowmeters, such as measurement of two-phase flow, partial empty tube conditions, and batching from empty. Refer to PSS 1-2B7 A or PSS 1-2B7 C for further data and specifications relating to the Model CFT50 or CFT51, respectively.

PRODUCT PATENTS

This product and associated components are protected by one or more of the following US patents: 6311136, 6505519, 6507791, 6754594, 6758102, 6917887, 6950760, 6981424, 7124646, 7136761, 7146280, 7404336, 7505854, 7571062, 7784360, 8000906.

APPLICATION VERSATILITY

This brand of Coriolis flowmeter is insensitive to varying process conditions. In addition to accurately measuring liquid, it can also be used in applications with entrained air, non-Newtonian fluids, viscous and abrasive fluids, slurries, and liquefied gases.

DESIGNED FOR SANITARY SERVICE

These flowtubes comply with the 3-A standards for use in sanitary applications. They are suited for general Food and Drug Industry applications. Process-wetted parts are 316L stainless steel. The flowtube's internal surface is free from internal crevices, and allows for in-line cleaning using various combinations of cleaning solutions at temperatures dependent upon limitation of the end connection seals. Refer to Model Codes for the numerous sanitary configurations available.

REAL WORLD CONDITIONS

Exemplified by:

- ▶ High accuracy at realistic nominal velocities means reduced erosion
- ▶ Immunity to external pipe vibrations
- ▶ Low pressure loss
- ▶ Low velocities mean lower pumping costs
- ▶ High accuracy over a wide range of fluid densities
- ▶ Immune to entrained air
 - Continues to measure during two phase flow
 - No zero drifting with CFT50/CFT51 DSP transmitter
 - Tubes can be blown dry with NO false indications of flow

HIGH FLOWTUBE RELIABILITY

Assured because of:

- ▶ Advanced CAE technology with computer modeling
- ▶ Rigid center flowtube body
- ▶ Automated orbital welding and brazing
- ▶ Low stressed welds and brazed joints
- ▶ All welds performed by qualified welders
- ▶ Annealed process-wetted welds
- ▶ Thick walled tubes
- ▶ Tubes in torsion (not bending) with low stress throughout, particularly at welds and brazed joints
- ▶ Realistic velocities
- ▶ Hydrostatically tested at 1.5 times the rated maximum pressure
- ▶ Meets NACE requirements

MANY FLOWTUBE CONFIGURATIONS

Model	Size	End Connections (a)
CFS10 (Single Path)	3 mm (1/8 in)	T only
	6 mm (1/4 in)	T, F, or S
	15 mm (1/2 in)	T, F, or S
	20 mm (3/4 in)	T, F, or S
	25 mm (1 in)	F or S
	40 mm (1 1/2 in)	F or S
CFS20 (Dual Path)	50 mm (2 in)	F or S
	40 mm (1 1/2 in)	F only
	80 mm (3 in)	F or S

- a. T = Threaded
F = Flanged (ANSI or EN 1092)
S = Sanitary (DIN coupling or quick disconnect coupling)

TAMPERPROOF SEALING OPTION

Tamperproof sealing of the terminal box cover is provided by selecting option -S.

WEIGHTS AND MEASURES CUSTODY TRANSFER OPTIONS -T AND -D

Optional selection -T provides for Weights and Measures Custody Transfer per NIST Handbook 44. (An NTEP approved label is also applied to the flowtube.) This option incorporates the Tamperproof Sealing Option -S, and must be combined with the CFT50/CFT51 Custody Transfer Option -T.

Optional Selection -D provides for the Weights and Measures Industry Canada Approval option. (A Weights and Measures Industry Canada approved label is also applied to the flowtube.) This option incorporates the Tamperproof Sealing Option -S, and must be combined with the CFT51 Transmitter Weights and Measures Industry Canada Approval Option -D.

FlowExpertPro™

The FlowExpertPro software is primarily used to size Foxboro flowmeters. It also ensures that the user has selected the proper flowmeter type for an application.

This meter selection website is a free tool for all users, without the need for registration. In addition to flowmeter selection and sizing, FlowExpertPro includes the following features:

- ▶ Incorporates a large library of the physical properties of typical process fluids.
- ▶ Displays results in tabular or graphic format.
- ▶ Allows user to save, print, or E-mail results.
- ▶ Provides reference to applicable flowmeter PSSs and other related flowmeter documentation.

The FlowExpertPro program calculates minimum and maximum flow rates, rangeability, pressure loss, and Reynolds Number, using established flow equations. It also allows for material and flange selection, and provides ANSI or metric flange recommendations for predicted flow pressure and temperature. Visit www.FlowExpertPro.com to access this program, or contact Global Customer Support for further information and technical support.

OPERATING CONDITIONS (FLOWTUBE ONLY)

Influence	Reference Operating Conditions	Normal Operating Condition Limits	Transportation and Storage Limits
Process Temperature	Water at 23 ±8°C (73 ±13°F)	-200 and +180°C (a) (-328 and +356°F) (a)	Not Applicable
Process Pressure	Water at 100 to 500 kPa (15 to 75 psi)	Refer to Table 3 and Table 4	Not Applicable
Ambient Temperature (b)	23 ±2°C (73 ±3°F)	-40 and +85°C (c) (d) (-40 and +185°F) (c) (d)	-40 and +85°C (-40 and +185°F)
Ambient Pressure	100 kPa (14.7 psia)	70 and 108 kPa (10.1 and 15.7 psia)	70 and 108 kPa (10.1 and 15.7 psia)
Relative Humidity	50 ±10%	5 and 100% (e)	0 and 100% Noncondensing

- a. The -200°C (-328°F) operating limit temperature is achievable when the Cryogenic Service option is selected. See Model Code and Optional Selections section.
- b. Refer to the Electrical Safety Specifications section for a restriction in ambient temperature with certain electrical certifications.
- c. Where lagging or heat tracing of flowtube is involved, the case temperature may exceed these limits.
- d. PVC insulated cable is suitable for ambient temperatures from -20 to +80°C (-4 to +176°F).
FEP insulated cable is suitable for ambient temperatures from -40 to +85°C (-40 to +185°F).
- e. 100% relative humidity value includes condensation.

SYSTEM PERFORMANCE SPECIFICATIONS

The following system performance specifications are for Reference Operating Conditions unless otherwise specified. Refer to PSS 1-2B7 A or PSS 1-2B7 C for Model CFT50 or CFT51 Digital Coriolis Mass Flow Transmitter specifications, respectively.

**Accuracy - Mass Flow Rate (Liquids)
(Includes Linearity, Hysteresis, and Repeatability)**

±0.10% + Zero Instability

Accuracy in % of rate is therefore,

$$\text{Accuracy} = \pm 0.10\% + \left(\frac{\text{Zero Instability}}{\text{Mass Flow Rate}} \times 100 \right)\%$$

For example, for a 3/4 inch flowtube, the measured Mass Flow Rate value of a liquid is 50 lb/min; then from Table 1, Zero Instability for a 3/4 inch flowtube is 0.010 lb/min; and therefore the accuracy in % of Rate, using the liquid equation, is:

$$\pm 0.10\% + \left(\frac{0.010 \text{ lb/min}}{50 \text{ lb/min}} \times 100 \right)\% = \pm 0.12\%$$

Therefore, the accuracy of the measured liquid is ±0.12% of the measured mass flow rate value of 50 lb/min, or

$$\pm 0.12\% \times (50 \text{ lb/min}) = \pm 0.06 \text{ lb/min}$$

**Accuracy - Mass Flow Rate (Gases)
(Includes Linearity, Hysteresis, and Repeatability)**

±0.50% + Zero Instability

Accuracy in % of rate is therefore,

$$\text{Accuracy} = \pm 0.50\% + \left(\frac{\text{Zero Instability}}{\text{Mass Flow Rate}} \times 100 \right)\%$$

Table 1. Zero Instability

Flowtube Model	Flowtube Size	Zero Instability (a)	
		kg/min	lb/min
CFS10	3 mm (1/8 in)	0.00016	0.00035
	6 mm (1/4 in)	0.00045	0.001
	15 mm (1/2 in)	0.00204	0.0045
	20 mm (3/4 in)	0.00454	0.010
	25 mm (1 in)	0.00907	0.020
	40 mm (1 1/2 in)	0.0204	0.045
	50 mm (2 in)	0.0340	0.075
CFS20	40 mm (1 1/2 in)	0.0204	0.045
	80 mm (3 in)	0.0907	0.200

a. In the accuracy equation, Zero Instability and Mass Flow Rate units must be the same.

Accuracy – Process Temperature

±1°C (±1.8°F) for temperatures between -60 and +100°C (-76 and +212°F)

Or

±3°C (±5.4°F) for temperatures from -130 to -60°C (-202 to -76°F) and from 100 to 180°C (212 to 356°F).

Accuracy – Density

Flowtube Size		Accuracy - Density (a) (b)
mm	in	
3 to 80	1/8 to 3	±0.0005 g/cc

- a. Density Accuracy is at Reference Operating Conditions.
- b. May require in situ calibration for maximum accuracy.

FUNCTIONAL SPECIFICATIONS

Table 2. Mass Flow Rate Ranges

Flowtube Model	Nominal Flowtube Size		Mass Flow Rate Ranges			
			Nominal		Extended Upper Range (a)	
	mm	in	kg/min	lb/min	kg/min	lb/min
CFS10	3	1/8	0.03 to 3.2	0.07 to 7	7	15
	6	1/4	0.09 to 9	0.2 to 20	22	48
	15	1/2	0.4 to 40	0.9 to 90	73	160
	20	3/4	0.9 to 90	2 to 200	119	261
	25	1	1.8 to 180	4 to 400	244	536
	40	1 1/2	4 to 400	9 to 900	607	1335
	50	2	7 to 700	15 to 1500	1023	2250
CFS20	40	1 1/2	4 to 400	9 to 900	485	1070
	80	3	18 to 1815	40 to 4000	2040	4500

a. Extended upper range is based on a fluid specific gravity of 0.8 at a temperature of 100°C (212°F). To find the extended upper range at other specific gravities and temperatures, contact Global Customer Support.

Process Temperature/Pressure Limits

Process temperature/pressure limits are limited by either the maximum flowtube values or the maximum end connection values, whichever are less. Refer to Table 3 and Table 4.

Process Density

Process fluid density ranges from 200 to 3000 kg/m³ (12.5 to 187 lb/ft³); or a specific gravity range of 0.2 to 3. Note that a specific gravity of 1 corresponds to a fluid density of 1000 kg/m³ (62.4 lb/ft³).

Pressure Loss - FlowExpertPro.com

To determine pressure loss or sizing for your application, merely have your process information available and visit the FlowExpertPro.com web site.

Table 3. Flowtube Process Temperature and Pressure Limits with Threaded End Connections (a)

Nominal Flowtube Size		Process Temperature		Maximum Working Pressure (MWP)			
				316/316L ss		Nickel Alloy (b)	
mm	in	°C	°F	barg	psig	barg	psig
3 and 6	1/8 and 1/4	40	100	179	2600	217	3150
		100	200	155	2243	217	3150
		150	300	140	2026	213	3050
		180	356	133	1932	207	3010
15 and 20 (b)	1/2 and 3/4 (b)	40	100	100	1440	103	1500
		100	200	85	1240	103	1500
		150	300	78	1120	100	1455
		180	356	75	1080	98	1435

a. Linear interpolation is acceptable.

b. Nickel alloy (equivalent to Hastelloy® C-22) not available with 20 mm (3/4 inch) flowtube.

Table 4. Flowtube Process Temperature and Pressure Limits with Flanged End Connections (a)

End Connection Type	Process Temp.	MWP (b)	
		316/316L ss	Nickel Alloy (c)
ANSI; Class 150 Flange	100°F	275 psig	290 psig
	200°F	240 psig	260 psig
	300°F	215 psig	230 psig
	356°F	204 psig	213 psig
ANSI; Class 300 Flange	100°F	720 psig	750 psig
	200°F	620 psig	750 psig
	300°F	560 psig	730 psig
	356°F	535 psig	713 psig
ANSI; Class 600 Flange	100°F	1440 psig	1500 psig
	200°F	1240 psig	1500 psig
	300°F	1120 psig	1455 psig
	356°F	1067 psig	1421 psig
EN 1092; PN 10/16 Flange	RT (d)	16 barg	16 barg
	100°C	16 barg	16 barg
	150°C	14.5 barg	14.5 barg
	180°C	13.8 barg	13.8 barg
EN 1092; PN 25/40 Flange	RT (d)	40 barg	40 barg
	100°C	40 barg	40 barg
	150°C	36.3 barg	36.3 barg
	180°C	34.7 barg	34.7 barg
EN 1092; PN 100 Flange	RT (d)	100 barg	100 barg
	100°C	100 barg	100 barg
	150°C	90.9 barg	90.9 barg
	180°C	86.9 barg	86.9 barg
ANSI B2.1; Threaded (NPT)	MWP limited by threaded end connection limits per Table 3.		
Quick Disconnect Sanitary Coupling or DIN 11851 Coupling	Maximum working pressure is 10 barg at 25°C (145 psig at 77°F). (e)		

- a. Linear interpolation is acceptable.
- b. See Model Codes for flowtube configurations available with 316 ss, 316L ss, and nickel alloy (equivalent to Hastelloy® C-22) end connections.
- c. Equivalent to Hastelloy® C-22.
- d. RT = Reference Temperature = -10 to +100°C.
- e. If higher MWPs are required, contact Global Customer Support.

PHYSICAL SPECIFICATIONS

Flowtube to Transmitter Interface

The flowtube has a terminal for the local earth (ground) connection. For signal connections, the flowtube is provided with an integrally mounted electrical junction box that meets the weatherproof rating of IP66/67 as defined by IEC 60529, and provides the environmental and corrosion resistant rating of NEMA Type 4X. The junction box contains a pair of 6-position feedthrough type terminal blocks. The terminal blocks are connected to the flowtube through a hermetic seal with properly spaced intrinsically safe wiring. An internally threaded 3/4 NPT conduit fitting at the top of the junction box is provided for signal cabling.

Tamperproof sealing of the junction box cover is provided when selecting Tamperproof Sealing Option -S, Weights and Measures Custody Transfer Option -T, or Weights and Measures Industry Canada Approval Option -D.

When selecting Option -T, an NTEP approved label is applied to the flowtube. Selecting Option -T requires that the CFT50/CFT51 Transmitter Custody Transfer Option -T is also selected. Similarly, selecting Option -D for Weights and Measures Industry Canada Approval requires that you also select the CFT51 Transmitter Weights and Measures Industry Canada Approval Option -D.

Interconnecting cable to the transmitter is not provided with the tube. However, FEP or PVC jacketed cable can be ordered separately for this purpose. Refer to the Cable Model Code for specifications and ordering instructions.

NOTE

If conduit is used (required with cryogenic option), a watertight conduit connector and conduit drip loop are required at the junction box to prevent collection of condensate. If conduit is not used, a watertight cable grip and cable drip loop are recommended.

Figure 1. Tamperproof Sealing of Junction Box Cover provided with Option -S, Option -T, and Option -D

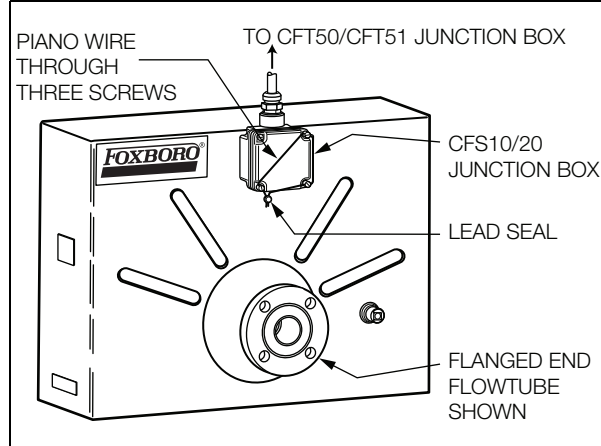

Dual Seal Certification

The CFS flowtubes are dual seal approved to meet ANSI/ISA 12.27.01 requirements when connected to a CFT50/CFT51 transmitter.

NACE Certification

The CFS10 and CFS20 flowtubes have been designed, and materials selected, to meet the requirements of NACE Standard MR0175-2003 for use in H₂S in Sour Oilfield Environments. The design and materials of construction also comply with NACE Standard MR0103-2007 for use in Corrosive Petroleum Refining Environments.

Junction Box Extension Kit for Steam Jacket or Flowtube Insulation

The normal clearance between the outside surface of the tube and junction box is a nominal 12.7 mm (1/2 in). In order to adequately accommodate a steam jacket or insulation enveloping the tube’s outside surface, this clearance can be increased to 102 mm (4 in) by using the junction box extension kit shown in Figure 2. See applicable installation instructions and parts list for further details.

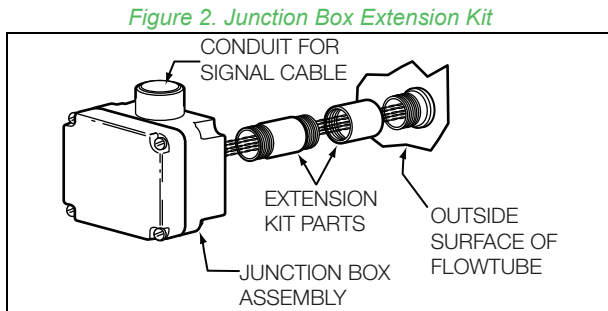

Flowtube Enclosure

AISI Type 304 stainless steel (304 ss) with a matte finish. Seams are welded and the enclosure is free from water and dust retaining cavities.

Ingress Protection

Hermetically sealed, welded flowtube enclosure provides ingress protection at internal pressure less than atmospheric pressure; 70 kPa (10.15 psia).

Flowtube Mounting

Designed for mounting to a horizontal or vertical pipe. There will be fluid draining when the flowtube is mounted vertically and there is an upward flow.

Dimensions

For 3-A Sanitary compliant installation, the Flowtube MUST be installed in a vertical configuration.

Refer to section “DIMENSIONS – NOMINAL” on page 22.

Approximate Mass

Table 5. Approximate Mass with ANSI Class 150 Flanges (a)

Nominal Flowtube Size		Approximate Mass	
mm	in	kg	lb
3	1/8	Not Applicable	
6	1/4	9.5	21
15	1/2	11.8	26
20	3/4	18.6	41
25	1	22.7	50
40	1 1/2	53.5	118
50	2	77.6	171
80	3	111	244

a. See Model Codes for other flanges available with each flowtube size.

Table 6. Approximate Mass with Threaded or Sanitary Connections (a)

Nominal Flowtube Size		Approximate Mass	
mm	in	kg	lb
3	1/8	6.4	14
6	1/4	8.6	19
15	1/2	10.4	23
20	3/4	16.8	37
25	1	20.4	45
40	1 1/2	49.9	110
50	2	71.2	157
80	3	99.3	219

a. See Model Codes for end connections available with each flowtube size.

ELECTRICAL SAFETY SPECIFICATIONS

These flowtubes meet the electrical safety descriptions listed in the tables below. For detailed information or status of the Testing Laboratory approvals/certifications, contact Global Customer Support.

Table 7. Electrical Safety Specification (Applies to Flowtubes Used with CFT50 Only)

Testing Laboratory, Type of Protection, and Area Classification	Application Conditions (a)	Electrical Safety Design Code
ATEX intrinsically safe, II 2 G; EEx ib II B; Zone 1	Connected to CFT50-*****M or Q Mass Flow Transmitter	MMM
ATEX nonsparking, II 3 G; EEx nA II; Zone 2	Connected to CFT50-*****T Mass Flow Transmitter	LLL
CSA nonincendive for use in Class I, Division 2, Groups A, B, C, and D, hazardous locations	Connected to Model CFT50-*****L, P, or S Mass Flow Transmitter per MI 019-133/MI 019-141	CNN
FM intrinsically safe apparatus for Class I, Division 1, Groups C and D, hazardous locations	Connected to Model CFT50-*****K or N Mass Flow Transmitter per MI 019-133/MI 019-141	FBB
FM nonincendive for use in Class I, Division 2, Groups A, B, C, and D, locations	Connected to Model CFT50-*****K, N, or R Mass Flow Transmitter per MI 019-133/MI 019-141	FNN
Agency approvals or certifications are not required		ZZZ

a. Temperature Class is a function of process temperature. See Table 8.

Table 8. Process Temperature Range for Electrical Safety Design Codes When Used with CFT50

Flowtube Model	Flowtube Size		Ambient Temperature		Temp. Class	Process Temperature Range	
	mm	in	°C	°F		°C	°F
Process Temperature Range for Intrinsically Safe Electrical Safety Design Codes (MMM and FBB)							
CFS10	3 through 20	0.125 through 0.750	-20 to +60°	-4 to +140°	T2	-200 to +180°	-328 to +356°
					T3	-200 to +160°	-328 to +320°
					T4	-200 to +95°	-328 to +203°
					T5	-200 to +60°	-328 to +140°
					T6	-200 to +45°	-328 to +113°
	25 through 50	1.00 through 2.00	-20 to +60°	-4 to +140°	T2	-55 to +165°	-67 to +329°
					T3	-55 to +165°	-67 to +329°
					T4	-55 to +95°	-67 to +203°
					T5	-55 to +60°	-67 to +140°
					T6	-55 to +45°	-67 to +113°
CFS20	40 and 80	1.50 and 3.00	-20 to +60°	-4 to +140°	T2	-55 to +165°	-67 to +329°
					T3	-55 to +165°	-67 to +329°
					T4	-55 to +95°	-67 to +203°
					T5	-55 to +60°	-67 to +140°
					T6	-55 to +45°	-67 to +113°
Process Temperature Range for Electrical Safety Design Codes for Zone 2 or Division 2 (LLL, CNN, FNN)							
CFS10 and CFS20	All Flowtube Sizes		-40 to +85°	-40 to +185°	T3	-40 to +180°	-40 to +356°
					T4	-40 to +115°	-40 to +239°
					T5	-40 to +80°	-40 to +176°
					T6	-40 to +65°	-40 to +149°
Process Temperature Range for Electrical Safety Design Code ZZZ (Agency Approvals Not Required)							
CFS10 and CFS20	All Flowtube Sizes		-40 to +180°	-40 to +356°	N/A	-40 to +180°	-40 to +356°

Table 9. Electrical Safety Specification (Applies to Flowtubes Used with CFT51 Only)

Testing Laboratory, Type of Protection, and Area Classification	Application Conditions (a)	Electrical Safety Design Code
CSA/CSAus Division 1/Zone 0 Intrinsically Safe	Connected to CFT51 Electrical Safety Code CDA or CNA	CAA
CSA/CSAus Division 2/Zone 2 Non-Incendive	Connected to CFT51 Electrical Safety Code CDN or CNN	CCN
FM Division 1/Zone 0 Intrinsically Safe	Connected to CFT51 Electrical Safety Code FDA or FNA	FAA
FM Division 2/Zone 2 Non-Incendive	Connected to CFT51 Electrical Safety Code FDN or FNN	FFN
ATEX Intrinsic safe Ex ia/ic	Connected to CFT51 Electrical Safety Code ADA or ANA	AAA
ATEX Non Sparking Zone 2 Ex nA	Connected to CFT51 Electrical Safety Code ADN or ANN	ANN
IECEx Intrinsic safe Ex ia/ic	Connected to CFT51 Electrical Safety Code EDA or ENA	EAA
IECEx Non Sparking Zone 2 Ex nA	Connected to CFT51 Electrical Safety Code EDN or ENN	ENN
EAC Intrinsic Safe Ex ia/ic	Connected to CFT51 Electrical Safety Code RDA or RNA	RAA
EAC Non Sparking Zone 2 Ex nA	Connected to CFT51 Electrical Safety Code RDN or RNN	RNN
INMETRO Intrinsic Safe Ex ia/ic	Connected to CFT51 Electrical Safety Code BDA or BNA	BAA
INMETRO Non Sparking Zone 2 Ex nA	Connected to CFT51 Electrical Safety Code BDN or BNN	BNN
KOSHA Non Sparking Zone 2 Ex nA	Connected to CFT51 Electrical Safety Code KNN	KNN
Agency approvals or certifications not required		YYY

a. Temperature Class is a function of process temperature. See Table 10.

Table 10. Process Temperature Range for Electrical Safety Design Codes When Used with CFT51 (a)

Flowtube Model	Flowtube Size		Ambient Temperature		Temp. Class	Process Temperature Range	
	mm	in	°C	°F		°C	°F
Process Temperature Range for Intrinsically Safe Electrical Safety Design Codes (CAA, FAA, AAA, EAA, RAA, BAA)							
CFS10	3 through 20	0.125 through 0.750	-40 to +60°	-40 to +140°	T4	-200 to +180°	-328 to +356°
	25 through 50	1.00 through 2.00				-55 to +180°	-67 to +356°
CFS20	40 and 80	1.50 and 3.00				-55 to +180°	-67 to +356°
Process Temperature Range for Electrical Safety Design Codes for Zone 2 or Division 2 (CCN, FFN, ANN, ENN, RNN, BNN, KNN)							
CFS10 CFS20	All Flowtube Sizes		-40 to +60°	-40 to +140°	T4	-40 to +180°	-40 to +356°
Process Temperature Range for Electrical Safety Design Code YYY (Agency Approvals Not Required)							
CFS10 CFS20	All Flowtube Sizes		-40 to +180°	-40 to +356°	N/A	-40 to +180°	-40 to +356°

a. Protect the equipment from the temperature of the process such that the ambient temperature does not exceed 60°C (140°F).

MODEL CODE – CFS10 SERIES MASS FLOWTUBES

Description	Model
CFS10 Series Mass Flowtube (Not Supplied with Cable to Transmitter) (a)	CFS10
Nominal Flowtube and Flange Size	
3 mm (1/8 in); Threaded 1/4 NPT, ANSI B2.1 Connection	-02
6 mm (1/4 in)	-03
15 mm (1/2 in)	-05
20 mm (3/4 in)	-08
25 mm (1 in)	-10
40 mm (1 1/2 in)	-15
50 mm (2 in)	-20
Flowtube Wetted Material	
AISI Type 316L Stainless Steel (316L ss)	S
Nickel alloy (Not available with Flowtube Size Codes -08, -15, and -20)	H
End Connections	
Threaded, NPT, ANSI B2.1 (Not available with Flowtube Size Codes -10, -15, or -20)	A
ANSI, Class 150 Flange (Not Available with Flowtube Size Code -02) (b)	C
ANSI, Class 300 Flange (Not Available with Flowtube Size Code -02) (b)	D
ANSI, Class 600 Flange (Not Available with Flowtube Size Code -02) (b)	E
EN 1092, PN 10/16, 25/40 Flange (Not Available with Flowtube Size Code -02) (b) (c) (d)	F
EN 1092, PN 100 Flange (Not Available with Flowtube Size Code -02) (b)	J
Electrical Safety (See Electrical Safety Specifications Section)	
ATEX, II 2 G, EEx ib, IIB; T2–T6 (e)	MMM
ATEX, II 3 G, EEx nA, II; T3–T6 (e)	LLL
CSA, Nonincendive for use in Class I, Division 2, Groups A, B, C, and D (e)	CNN
FM, Intrinsically Safe, Class I, Division 1, Groups C and D (e)	FBB
FM, Nonincendive for Class I, Division 2, Groups A, B, C, and D (e)	FNN
No Electrical Certifications/Approvals, CFT50 (e)	ZZZ
CSA/CSAus Division 1/Zone 0 Intrinsically Safe (f)	CAA
CSA/CSAus Division 2/Zone 2 Non-Incendive (f)	CCN
FM Division 1/Zone 0 Intrinsically Safe (f)	FAA
FM Division 2/Zone 2 Non-Incendive (f)	FFN
ATEX Intrinsic safe Ex ia/ic (f)	AAA
ATEX Non Sparking Zone 2 Ex nA (f)	ANN
IECEX Intrinsic safe Ex ia/ic (f)	EAA
IECEX Non Sparking Zone 2 Ex nA (f)	ENN
EAC Intrinsic Safe Ex ia/ic (f)	RAA
EAC Non Sparking Zone 2 Ex nA (f)	RNN
INMETRO Intrinsic Safe Ex ia/ic (f)	BAA
INMETRO Non Sparking Zone 2 Ex nA (f)	BNN
KOSHA Non Sparking Zone 2 Ex nA (f)	KNN
No Electrical Certifications/Approvals, CFT51 (f)	YYY

MODEL CODE – CFS10 SERIES MASS FLOWTUBES (CONTINUED)

Description	Model
Optional Selections	
Bidirectional Flow Calibration (Standard Factory Calibration is one direction)	-B
Cryogenic Applications for Temperatures below -130°C (-202°F) (g)	-C
Calibrated for use with a CFT50/CFT51 Transmitter (Default Calibration) (c)	-E
Calibrated for use with a CFT10 or CFT15 Transmitter (c)	-F
Dual Calibrations, for use with a CFT10, CFT15, CFT50, or CFT51 Transmitter (c)	-G
Material Certification of Process Wetted Metal (Conforms to EN 10204 3.1 Equivalent to Cert D)	-M
Tamperproof sealing for Terminal Block Cover (h)	-S
Weights and Measures Custody Transfer/NTEP	-T
▶ Includes Tamperproof Sealing Option -S	
▶ Must be combined with CFT50/CFT51 Transmitter Option -T	
▶ Calibration Option -E must also be specified	
Weights and Measures Industry Canada Approvals	-D
▶ Includes Tamperproof Sealing Option -S	
▶ Must be combined with CFT51 Transmitter Option -D	
▶ Calibration Option -E must also be specified	
Radiography of Pressure Retaining Welds (i)	-X
Examples: CFS10-05SCFBB-BX; CFS10-10SFCNN-E	

- a. **IMPORTANT:** The flowtube is not supplied with cable for transmitter interconnection. Standard cable can be ordered separately. See Cable Model Code for ordering information.
- b. Size Code -03, 6 mm (1/4 in) Flowtube, supplied with a 15 mm (1/2 in) flange connection.
- c. Specify one of either -E, -F, or -G Calibration Options only.
- d. The PN 25/40 flange is used for PN 10/16 flange applications
- e. Applies to tubes used with CFT50 only.
- f. Applies to tubes used with CFT51 only.
- g. Safety Code FBB cannot be applied on sizes 02, -03, -10, -15, and -20 when the Cryogenic Option is selected.
- h. Option -S not available with Electrical Safety Codes MMM and LLL.
- i. Per ASME Section V Boiler/Pressure Vessel Code, Nondestructive.

MODEL CODE – CFS10 SERIES SANITARY MASS FLOWTUBES

Description	Model
CFS10 Series Sanitary Mass Flowtube (a)	CFS10
Nominal Flowtube and End Connection Size	
6 mm (1/4 in); Process Connection Size is 1/2 in	-03
15 mm (1/2 in); Process Connection Size is 1 in	-05
20 mm (3/4 in); Process Connection Size is 1 in	-08
25 mm (1 in); Process Connection Size is 1 in	-10
40 mm (1 1/2 in); Process Connection Size is 1 1/2 in	-15
50 mm (2 in); Process Connection Size is 2 in	-20
Flowtube Wetted Material	
AISI Type 316L ss prepared for Sanitary Applications. Complies with 3-A Standards	C
End Connections (Supplied in AISI Type 316 Stainless Steel Only)	
For Mating to DIN 11851 Coupling with External Thread (Not available with Flowtube Size Code -03)	N
For Mating to Tri-Clamp Type Quick Disconnect Coupling	P
Electrical Safety (See Electrical Safety Specifications Section)	
ATEX, II 2 G, EEx ib, IIB; T2–T6 (b)	MMM
ATEX, II 3 G, EEx nA, II; T3–T6 (b)	LLL
CSA, Nonincendive for use in Class I, Division 2, Hazardous Locations (b)	CNN
FM, Intrinsically Safe, Class I, Division 1, Groups C and D (b)	FBB
FM, Nonincendive for Class I, Division 2, Groups A, B, C, and D (b)	FNN
No Electrical Certifications/Approvals, CFT50 (b)	ZZZ
CSA/CSAus Division 1/Zone 0 Intrinsically Safe (c)	CAA
CSA/CSAus Division 2/Zone 2 Non-Incendive (c)	CCN
FM Division 1/Zone 0 Intrinsically Safe (c)	FAA
FM Division 2/Zone 2 Non-Incendive (c)	FFN
ATEX Intrinsic safe Ex ia/ic (c)	AAA
ATEX Non Sparking Zone 2 Ex nA (c)	ANN
IECEX Intrinsic safe Ex ia/ic (c)	EAA
IECEX Non Sparking Zone 2 Ex nA (c)	ENN
EAC Intrinsic Safe Ex ia/ic (c)	RAA
EAC Non Sparking Zone 2 Ex nA (c)	RNN
INMETRO Intrinsic Safe Ex ia/ic (c)	BAA
INMETRO Non Sparking Zone 2 Ex nA (c)	BNN
KOSHA Non Sparking Zone 2 Ex nA (c)	KNN
No Electrical Certifications/Approvals, CFT51 (c)	YYY

MODEL CODE – CFS10 SERIES SANITARY MASS FLOWTUBES (CONTINUED)

Description	Model
<p>Optional Selections</p> <p>Bidirectional Flow Calibration (Standard Factory Calibration is one direction)</p> <p>Calibrated for use with a CFT50/CFT51 Transmitter (Default Calibration) (d)</p> <p>Calibrated for use with a CFT10 or CFT15 Transmitter (d)</p> <p>Dual Calibrations, for use with a CFT10, CFT15, CFT50, or CFT51 Transmitter (d)</p> <p>Material Certification of Process Wetted Metal (Conforms to EN 10204 3.1 Equivalent to Cert D)</p> <p>Tamperproof sealing for Terminal Block Cover (e)</p> <p>Weights and Measures Custody Transfer/NTEP</p> <ul style="list-style-type: none"> ▶ Includes Tamperproof Sealing Option -S ▶ Must be combined with CFT50/CFT51 Transmitter Option -T ▶ Calibration Option -E must also be specified <p>Weights and Measures Industry Canada Approvals</p> <ul style="list-style-type: none"> ▶ Includes Tamperproof Sealing Option -S ▶ Must be combined with CFT51 Transmitter Option -D ▶ Calibration Option -E must also be specified <p>Example: CFS10-05CPFBB-BM</p>	<p>-B</p> <p>-E</p> <p>-F</p> <p>-G</p> <p>-M</p> <p>-S</p> <p>-T</p> <p>-D</p>

- a. **IMPORTANT:** The flowtube is not supplied with cable for transmitter interconnection. Standard cable can be ordered separately. See Cable Model Code for ordering information.
- b. Applies to tubes used with CFT50 only.
- c. Applies to tubes used with CFT51 only.
- d. Specify one of either -E, -F, or -G Calibration Options only.
- e. Option -S not available with Electrical Safety Codes MMM and LLL.

MODEL CODE – CFS20 SERIES MASS FLOWTUBES

Description	Model
CFS20 Series Mass Flowtubes (a)	CFS20
Nominal Flowtube and Flange Size	
40 mm (1 1/2 in)	-15
80 mm (3 in)	-30
Flowtube Wetted Material	
AISI Type 316L Stainless Steel (316L ss); with Size Code -30 only	S
Nickel alloy; (equivalent to Hastelloy® C-22) with Size Code -15 only	H
End Connections	
ANSI, Class 150 Flange	C
ANSI, Class 300 Flange	D
ANSI, Class 600 Flange	E
EN 1092, PN 40 Flange	F
EN 1092, PN 100 Flange	J
Electrical Safety (See Electrical Safety Specifications Section)	
ATEX, II 2 G, EEx ib, IIB; T2–T6 (b)	MMM
ATEX, II 3 G, EEx nA, II; T3–T6 (b)	LLL
CSA, Nonincendive for use in Class I, Division 2, Hazardous Locations (b)	CNN
FM, Intrinsically Safe, Class I, Division 1, Groups C and D (b)	FBB
FM, Nonincendive for Class I, Division 2, Groups A, B, C, and D (b)	FNN
No Electrical Certifications/Approvals, CFT50 (b)	ZZZ
CSA/CSAus Division 1/Zone 0 Intrinsically Safe (c)	CAA
CSA/CSAus Division 2/Zone 2 Non-Incendive (c)	CCN
FM Division 1/Zone 0 Intrinsically Safe (c)	FAA
FM Division 2/Zone 2 Non-Incendive (c)	FFN
ATEX Intrinsic safe Ex ia/ic (c)	AAA
ATEX Non Sparking Zone 2 Ex nA (c)	ANN
IECEX Intrinsic safe Ex ia/ic (c)	EAA
IECEX Non Sparking Zone 2 Ex nA (c)	ENN
EAC Intrinsic Safe Ex ia/ic (c)	RAA
EAC Non Sparking Zone 2 Ex nA (c)	RNN
INMETRO Intrinsic Safe Ex ia/ic (c)	BAA
INMETRO Non Sparking Zone 2 Ex nA (c)	BNN
KOSHA Non Sparking Zone 2 Ex nA (c)	KNN
No Electrical Certifications/Approvals, CFT51 (c)	YYY

MODEL CODE – CFS20 SERIES MASS FLOWTUBES (CONTINUED)

Description	Model
Optional Selections	
Bidirectional Flow Calibration (Standard Factory Calibration is one direction)	-B
Cryogenic Applications for Temperatures below -130°C (-202°F) (d)	-C
Calibrated for use with a CFT50/CFT51 Transmitter (Default Calibration) (e)	-E
Calibrated for use with a CFT10 or CFT15 Transmitter (e)	-F
Dual Calibrations, for use with a CFT10, CFT15, CFT50, or CFT51 Transmitter (e)	-G
Material Certification of Process Wetted Metal (Conforms to EN 10204 3.1 Equivalent to Cert D)	-M
Tamperproof sealing for Terminal Block Cover (f)	-S
Weights and Measures Custody Transfer/NTEP	-T
▶ Includes Tamperproof Sealing Option -S	
▶ Must be combined with CFT50/CFT51 Transmitter Option -T	
▶ Calibration Option -E must also be specified	
Weights and Measures Industry Canada Approvals (c)	-D
▶ Includes Tamperproof Sealing Option -S	
▶ Must be combined with CFT51 Transmitter Option -D	
▶ Calibration Option -E must also be specified	
Radiography of Pressure Retaining Welds (A copy of the Q.A. report is provided) (g)	-X
Examples: CFS20-15SCFBB-BX; CFS20-30SFCNN-E	

- a. IMPORTANT: The flowtube is not supplied with cable for transmitter interconnection. Standard cable can be ordered separately. See Cable Model Code for ordering information.
- b. Applies to tubes used with CFT50 only.
- c. Applies to tubes used with CFT51 only.
- d. Electrical Safety Code FBB cannot be applied on Flowtube Size -30 (3 in) when the Cryogenic Option is selected.
- e. Specify one of either -E, -F, or -G Calibration Options only.
- f. Option -S not available with Electrical Safety Codes MMM and LLL.
- g. Per ASME Section V Boiler/Pressure Vessel Code, Nondestructive.

MODEL CODE – CFS20 SERIES SANITARY MASS FLOWTUBES

Description	Model
CFS20 Series Sanitary Mass Flowtubes (a)	CFS20
Nominal Flowtube and End Connection Size 80 mm (3 in), Process Connection Size is 3 in	-30
Flowtube Wetted Material AISI Type 316L ss prepared for Sanitary Applications. Complies with 3-A Standards.	C
End Connections - supplied in AISI Type 316 stainless steel only For Mating to DIN 11851 Coupling with External Thread For Mating to Tri-Clamp Type Quick Disconnect Coupling	N P
Electrical Safety (See Electrical Safety Specifications Section) ATEX, II 2 G, EEx ib, IIB (b) ATEX, II 3 G, EEx nA, II (b) CSA, Nonincendive for use in Class I, Division 2, Hazardous Locations (b) FM, Intrinsically Safe, Class I, Division 1, Groups C and D (b) FM, Nonincendive for Class I, Division 2, Groups A, B, C, and D (b) No Electrical Certifications/Approvals, CFT50 (b) CSA/CSAus Division 1/Zone 0 Intrinsically Safe (c) CSA/CSAus Division 2/Zone 2 Non-Incendive (c) FM Division 1/Zone 0 Intrinsically Safe (c) FM Division 2/Zone 2 Non-Incendive (c) ATEX Intrinsic safe Ex ia/ic (c) ATEX Non Sparking Zone 2 Ex nA (c) IECEX Intrinsic safe Ex ia/ic (c) IECEX Non Sparking Zone 2 Ex nA (c) EAC Intrinsic Safe HEx ia/ic (c) EAC Non Sparking Zone 2 Ex nA (c) INMETRO Intrinsic Safe Ex ia/ic (c) INMETRO Non Sparking Zone 2 Ex nA (c) KOSHA Non Sparking Zone 2 Ex nA (c) No Electrical Certifications/Approvals, CFT51 (c)	MMM LLL CNN FBB FNN ZZZ CAA CCN FAA FFN AAA ANN EAA ENN RAA RNN BAA BNN KNN YY Y
Optional Selections Bidirectional Flow Calibration (Standard Factory Calibration is one direction) Calibrated for use with a CFT50/CFT51 Transmitter (Default Calibration) (d) Calibrated for use with a CFT10 or CFT15 Transmitter (d) Dual Calibrations, for use with a CFT10, CFT15, CFT50, or CFT51 Transmitter (d) Material Certification of Process Wetted Metal (Conforms to EN 10204 3.1 Equivalent to Cert D) Tamperproof sealing for Terminal Block Cover (e) Weights and Measures Custody Transfer/NTEP ▶ Includes Tamperproof Sealing Option -S ▶ Must be combined with CFT50/CFT51 Transmitter Option -T ▶ Calibration Option -E must also be specified Weights and Measures Industry Canada Approval (c) ▶ Includes Tamperproof Sealing Option -S ▶ Must be combined with CFT51 Transmitter Option -D ▶ Calibration Option -E must also be specified Examples: CFS20-30SCFBB-BX; CFS20-15SCFBB-G	-B -E -F -G -M -S -T -D

- IMPORTANT: The flowtube is not supplied with cable for transmitter interconnection. Standard cable can be ordered separately. See Cable Model Code for ordering instructions.
- Applies to tubes used with CFT50 only.
- Applies to tubes used with CFT51 only.
- Specify one of either -E, -F, or -G Calibration Options only.
- Option -S not available with Electrical Safety Codes MMM and LLL.

MODEL CODE – CABLE (RECOMMENDED)

Description	Model
Cable Insulation Material (a)	
PVC-Insulated Cable, -20 to +80°C (-4 to +176°F) Ambient Temperature	KFS1
FEP-Insulated Cable, -40 to +85°C (-40 to +185°F) Ambient Temperature	KFS2
Cable Length - Feet or Meters	
20 feet	-F0020
100 feet	-F0100
200 feet	-F0200
500 feet	-F0500
750 feet	-F0750
1000 feet	-F1000
6 meters	-M006
30 meters	-M030
60 meters	-M060
150 meters	-M150
225 meters	-M225
300 meters	-M300
Examples: KFS1-F0200 = 200 feet of PVC Cable; KFS2-M006 = 6 meters of FEP Cable	

a. See "Cable Specifications".

Cable Specifications

PVC Cable

Six twisted pairs of PVC-insulated, 22 AWG stranded, tinned, copper wire. Each pair has an aluminum-polyester shield with drain wire. Cable has a chrome-PVC outer jacket with ambient temperature limits of -20 to +80°C (-4 to +176°F). One end of cable is dressed and ready for connection to transmitter. Voltage rating is 30 V ac.

FEP Cable

Six twisted pairs of FEP-insulated 22 AWG stranded, tinned, copper wire. Each pair has an aluminum-polyester shield with drain wire. Cable has an FEP outer jacket with ambient temperature limits of -40 to +85°C (-40 to +185°F). One end of cable is dressed and ready for connection to transmitter. Voltage rating is 30 V ac.

Table 11. Flowtube Model and Size vs. End Connection Configurations Available

Flowtube Model	Flowtube Size Code	Available with End Connection Codes:							
		Threaded Code	Flanged Code					Sanitary Code	
		A	C	D	E	F	J	N	P
CFS10	02	Yes	No	No	No	No	No	No	No
	03	Yes	Yes	Yes	Yes	Yes	Yes	No	Yes
	05	Yes	Yes	Yes	Yes	Yes	Yes	Yes	Yes
	08	Yes	Yes	Yes	Yes	Yes	Yes	Yes	Yes
	10	No	Yes	Yes	Yes	Yes	Yes	Yes	Yes
	15	No	Yes	Yes	Yes	Yes	Yes	Yes	Yes
	20	No	Yes	Yes	Yes	Yes	Yes	Yes	Yes
CFS20	15	No	Yes (a)	Yes (a)	Yes (a)	Yes (a)	Yes (a)	No	No
	30	No	Yes (b)	Yes (b)	Yes (b)	Yes (b)	Yes (b)	Yes	Yes

a. Model CFS20 Size Code 15 (flanged) only available with nickel alloy (equivalent to Hastelloy® C-22) wetted material.

b. Model CFS20 Size Code 30 (flanged) only available with 316L ss wetted material.

DIMENSIONS – NOMINAL

CFS10 AND CFS20 FLANGED END FLOWTUBES
6 to 80 mm (1/4 to 3 in) SIZES

mm
in

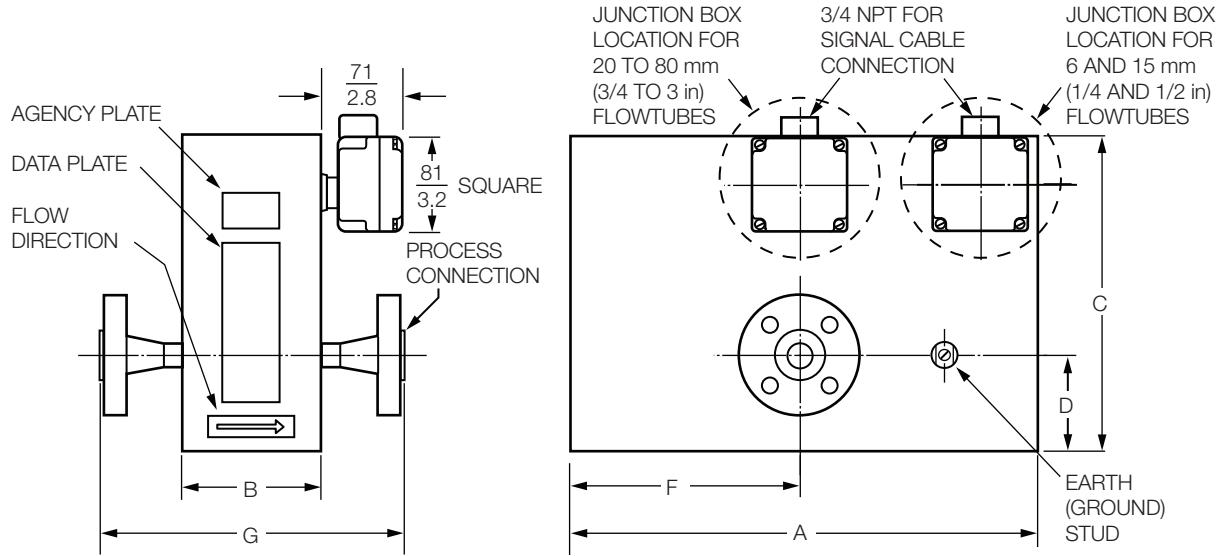

Flowtube Model	Flowtube Size	Dimensions - Nominal (a)				
		Dim. A	Dim. B	Dim. C	Dim. D	Dim. F
CFS10	6 mm (1/4 in)	411 16.2	160 6.3	231 9.1	30 1.2	206 8.1
	15 mm (1/2 in)	417 16.4	122 4.8	277 10.9	84 3.3	208 8.2
	20 mm (3/4 in)	518 20.4	163 6.4	391 15.4	12.2 4.8	259 10.2
	25 mm (1 in)	518 20.4	163 6.4	391 15.4	12.2 4.8	259 10.2
	40 mm (1 1/2 in)	704 27.7	241 9.5	457 18.0	130 5.1	353 13.9
	50 mm (2 in)	808 31.8	282 11.1	516 20.3	150 5.9	404 15.9
CFS20	40 mm (1 1/2 in)	518 20.4	163 6.4	391 15.4	12.2 4.8	259 10.2
	80 mm (3 in)	808 31.8	282 11.1	516 20.3	150 5.9	404 15.9

a. See next page for Dimension G.

Flowtube Model	Flowtube Size	Dimension G with the Following Flange Types				
		ANSI Class 150	ANSI Class 300	ANSI Class 600	EN 1092 PN 40	EN 1092 PN 100
CFS10	6 mm (1/4 in)	$\frac{264}{10.4}$	$\frac{264}{10.4}$	$\frac{264}{10.4}$	$\frac{264}{10.4}$	$\frac{264}{10.4}$
	15 mm (1/2 in)	$\frac{239}{9.4}$	$\frac{249}{9.8}$	$\frac{262}{10.3}$	$\frac{262}{10.3}$	$\frac{264}{10.4}$
	20 mm (3/4 in)	$\frac{290}{11.4}$	$\frac{300}{11.8}$	$\frac{312}{12.3}$	$\frac{305}{12.0}$	$\frac{312}{12.3}$
	25 mm (1 in)	$\frac{292}{11.5}$	$\frac{305}{12.0}$	$\frac{317}{12.5}$	$\frac{300}{11.8}$	$\frac{317}{12.5}$
	40 mm (1 1/2 in)	$\frac{391}{15.5}$	$\frac{406}{16.0}$	$\frac{411}{16.2}$	$\frac{406}{16.0}$	$\frac{411}{16.2}$
	50 mm (2 in)	$\frac{434}{17.1}$	$\frac{447}{17.6}$	$\frac{467}{18.4}$	$\frac{436}{17.2}$	$\frac{444}{17.5}$
CFS20	40 mm (1 1/2 in)	$\frac{356}{14.0}$	$\frac{368}{14.5}$	$\frac{370}{14.6}$	$\frac{368}{14.5}$	$\frac{370}{14.6}$
	80 mm (3 in)	$\frac{508}{20.0}$	$\frac{525}{20.7}$	$\frac{546}{21.5}$	$\frac{525}{20.7}$	$\frac{571}{22.5}$

CFS10 AND CFS20 SANITARY END FLOWTUBES
(WITH END CONNECTION CODE N)
6 to 80 mm (1/4 to 3 in) SIZES

mm
in

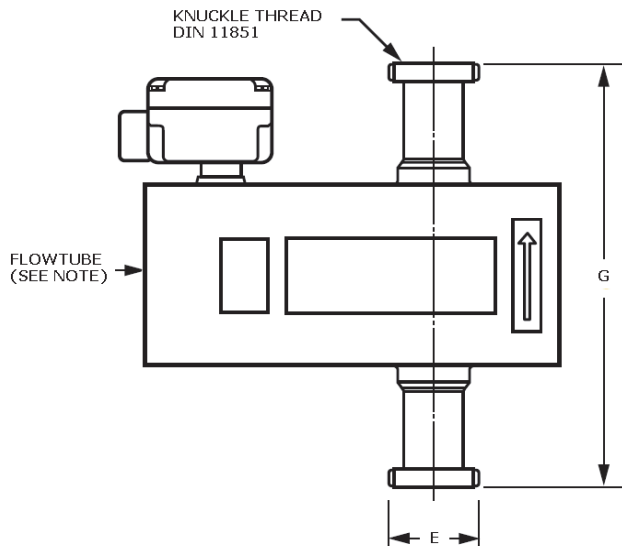

Sanitary End Flowtubes End Connection Code N (a)			
Flowtube Model	Flowtube Size	Dimensions	
		Dim. E	Dim. G
CFS10	6 mm (1/4 in)	Not Applicable	Not Applicable
	15 mm (1/2 in)	$\frac{53}{2.1}$	$\frac{284}{11.2}$
	20 mm (3/4 in)	$\frac{53}{2.1}$	$\frac{290}{11.4}$
	25 mm (1 in)	$\frac{51}{2.0}$	$\frac{320}{12.6}$
	40 mm (1 1/2 in)	$\frac{66}{2.6}$	$\frac{427}{16.8}$
	50 mm (2 in)	$\frac{79}{3.1}$	$\frac{457}{18.0}$
CFS20	80 mm (3 in)	$\frac{109}{4.3}$	$\frac{498}{19.6}$

a. Code N is a DIN coupling with external thread, DIN 11851.

NOTES:

1. For other flowtube dimensions, see previous pages.
2. For 3-A compliant installation, Flowtube MUST be installed in a vertical configuration, as shown above (note direction of flow arrow).

CFS10 AND CFS20 SANITARY END FLOWTUBES
(WITH END CONNECTION CODE P)
6 to 80 mm (1/4 to 3 in) SIZES

mm
in

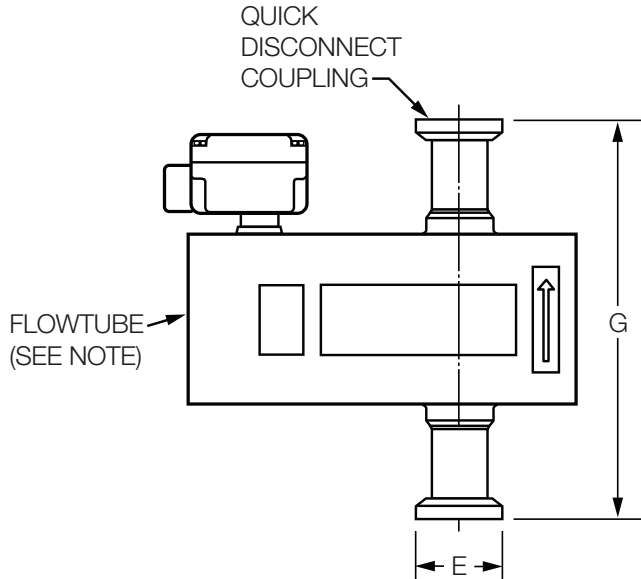

Sanitary End Flowtubes End Connection Code P (a)			
Flowtube Model	Flowtube Size	Dimensions	
		Dim. E	Dim. G
CFS10	6 mm (1/4 in)	<u>24.9</u> 0.98	<u>274</u> 10.8
	15 mm (1/2 in)	<u>50.3</u> 1.98	<u>249</u> 9.8
	20 mm (3/4 in)	<u>50.3</u> 1.98	<u>290</u> 11.4
	25 mm (1 in)	<u>50.3</u> 1.98	<u>287</u> 11.3
	40 mm (1 1/2 in)	<u>50.3</u> 1.98	<u>386</u> 15.2
	50 mm (2 in)	<u>63.5</u> 2.50	<u>414</u> 16.3
CFS20	80 mm (3 in)	<u>90.9</u> 3.58	<u>4.32</u> 17.0

- a. Code P mates with a Tri-Clamp type quick disconnect coupling
- 1/4 in size mates with 1/2-inch ferrule
 - 1/2 to 1 1/2 in sizes mate with 1-inch ferrule
 - 2 in size mates with 2-inch ferrule
 - 3-in size mates with 3-inch ferrule.

NOTES:

1. For flowtube dimensions other than those indicated above, refer to the Dimensions - Nominal section for flanged end flowtubes. Also, see the next page for threaded end flowtubes. For other flowtube dimensions, see the previous pages.
2. For 3-A compliant installation, the flowtube MUST be installed in a vertical configuration, as shown above (note the direction of the flow arrow).

CFS10 THREADED END FLOWTUBE
3 mm (1/8 in) SIZE

mm
in

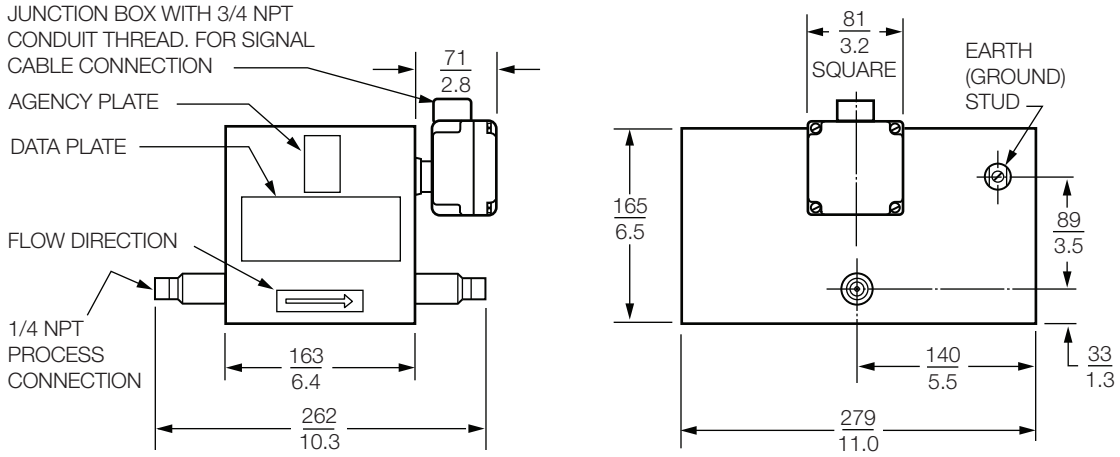

CFS10 THREADED END FLOWTUBES
6, 15, and 20 mm (1/4, 1/2, and 3/4 in) SIZES

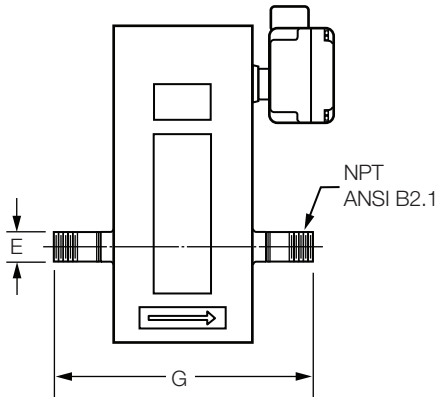

Threaded End Flowtubes			
Flowtube Model	Flowtube Size	Dimensions	
		Dim. E	Dim. G
CFS10	6 mm (1/4 in)	1/4 NPT	$\frac{224}{8.8}$
	15 mm (1/2 in)	1/2 NPT	$\frac{211}{8.3}$
	20 mm (3/4 in)	3/4 NPT	$\frac{259}{10.2}$

NOTE:
For other flowtube dimensions, see previous pages.

NOTES

ORDERING INSTRUCTIONS

1. Model Number – Flowtube
2. Model Number – Cable, if required
3. Model Number of CFT50 or CFT51 Transmitter, if required; see PSS 1-2B7 A or PSS 1-2B7 C, as applicable.
4. Flow Data (rate, pressure, temperature, etc.)
5. Junction Box Extension Kit (contact Global Customer Support, if required)
6. User Tag Data

FLOWEXPERTPRO SIZING APPLICATION

FlowExpertPro.com



Mobile application



OTHER FOXBORO PRODUCTS

The Foxboro product lines offer a broad range of measurement and instrument products, including solutions for pressure, flow, analytical, temperature, positioning, controlling, and recording. For a list of these offerings, visit our web site at:

www.schneider-electric.com

Schneider Electric Systems USA, Inc.
38 Neponset Avenue
Foxboro, MA 02035
United States of America
<http://www.schneider-electric.com>

Global Customer Support
Inside U.S.: 1-866-746-6477
Outside U.S.: 1-508-549-2424
<https://pasupport.schneider-electric.com>

Copyright 1997-2017 Schneider Electric Systems USA, Inc. All rights reserved.

Schneider Electric, Foxboro, and FlowExpertPro are trademarks of Schneider Electric Systems USA, Inc., its subsidiaries, and affiliates. All other trademarks are the property of their respective owners.

Life Is On

Foxboro[®]

by Schneider Electric